

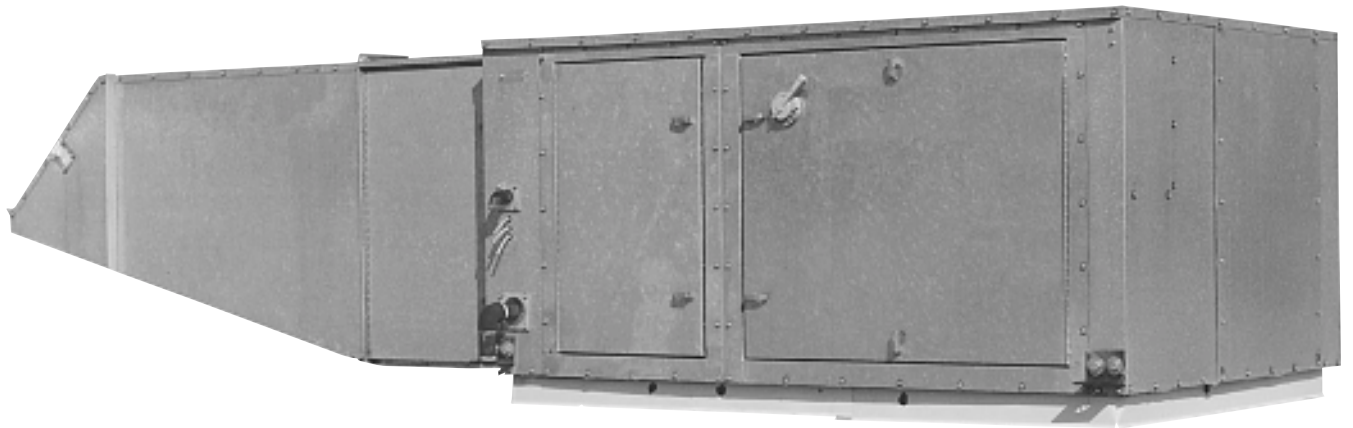

Make-Up Air Units

Direct-Fired Outdoor
Model DFOA





Introduction

Why Use Trane Make-Up Air Units?

To help relieve negative pressure inside commercial and industrial facilities, such as factories, garages, packing plants, kitchens, bowling alleys, and welding and foundry areas. Trane's make-up air units offer a wide range of cfm, from 1,600 to 64,000, and gas-fired burners with capacities from 131,000 Btuh to 7,748,000 Btuh. These ranges offer excellent variety when selecting a unit that will fill both the owner's needs and those of the specifying engineer. These units are flexible in that they can be located indoors or outdoors, and either curb or grade mounted.

All standard units include the necessary controls for operation, such as a flame safeguard, an air proving differential switch, a high temperature limit switch, and an ignition transformer. Component parts are of the highest quality. Each unit has overlapping, fail-safe protection devices to handle failures should they occur. Each unit is factory tested before it ships, and is designed to provide years of reliable, low maintenance operation.

Units are built with UL approved components, where applicable. Special gas controls can be furnished to comply with FM or IRI requirements.

Contents

Introduction	2
Features and Benefits	4
Unit Configurations	6
Application Considerations	7
Model Number Description	8
Performance Data	9
Gas Piping	11
Controls	16
Electric Power	18
Dimension and Weights	19
Mechanical Specifications	36
Options	37
Accessories	43

Features and Benefits

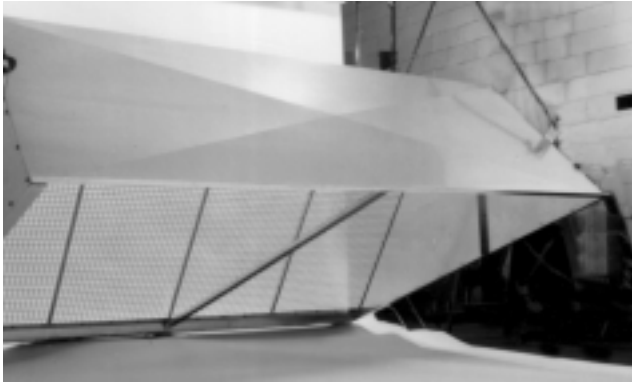

① *Supply air intake view showing inlet hood and birdscreen*

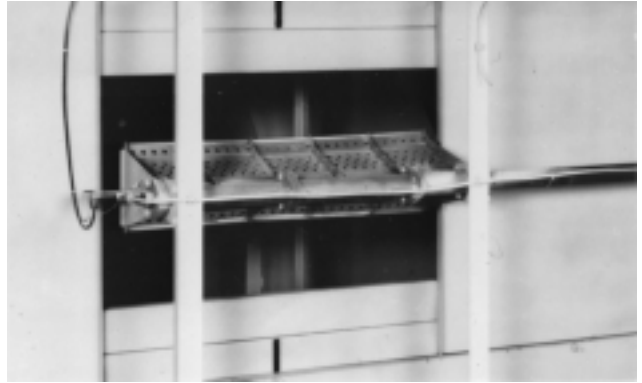

② *Gas burner section*

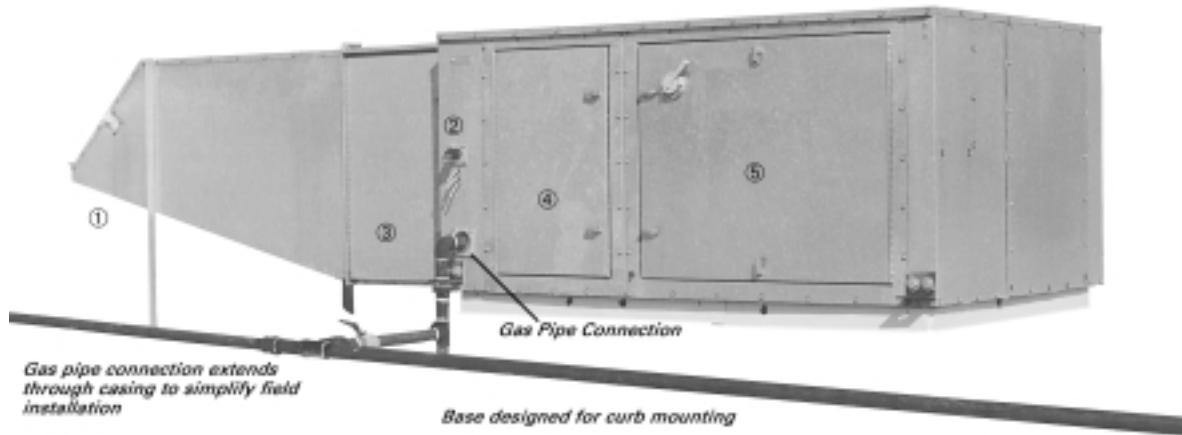

③ *Optional inlet damper with V-bank filter*



④ *Factory assembled gas manifold compartment*

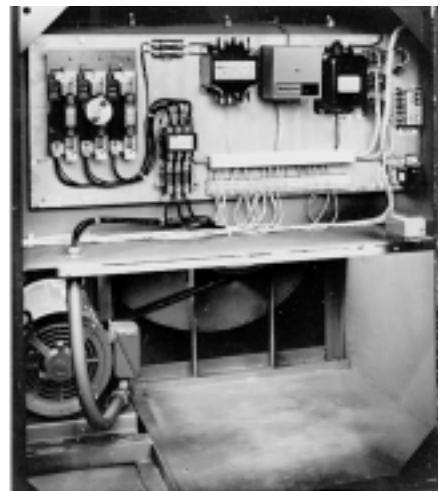

⑤ *Access compartment to control panel and fan motor.*

Note: Fan motor panel has been removed for photograph.



Features and Benefits

Basic Unit

Feature:
Casing with galvanized finish
Benefit:
Rust problem is greatly reduced

Feature:
Watertight construction
Benefit:
Designed for indoor or outdoor mounting

Feature:
Access doors are hinge mounted with industrial type hardware
Benefit:
Provides simple access to service compartments without removing sheet metal screws and panels

Feature:
Adjustable motor mount
Benefit:
Belt tension can be field adjusted for maximum belt life and for motor speed adjustment

Feature:
Basic unit is factory assembled and wired
Benefit:
Reduces field installation cost

Feature:
All fuses factory furnished
Benefit:
Delay at start-up eliminated

Feature:
Factory tested before being shipped
Benefit:
Eliminates majority of field start-up problems caused by defective controls

Feature:
No flues or stacks are used
Benefit:
Eliminates backdraft and dangerous contaminants from entering the space

Gas-Fired Unit

Feature:
Many standard, natural gas burning units bear the ETL label. Contact factory for verification.
Benefit:
Meets certain insurance requirements

Feature:
Optional temperature control systems available
Benefit:
Select system to satisfy application

Feature:
Optional dual fuel gas manifold
Benefit:
Standby flexibility in case natural gas supply is interrupted

Feature:
Optional construction provides return air cycle
Benefit:
Maximum 80 percent return air cycle results in fuel economy for pressurized heating systems and eliminates need for two-speed fan operation. Minimizes heating costs.

Unit Configurations

Horizontal Configurations

For all arrangements shown, the gas piping and controls are on the near side. Selected horizontal units are available with special options — cooling coils (DX, chilled water), steam and electric coils, no burner section.

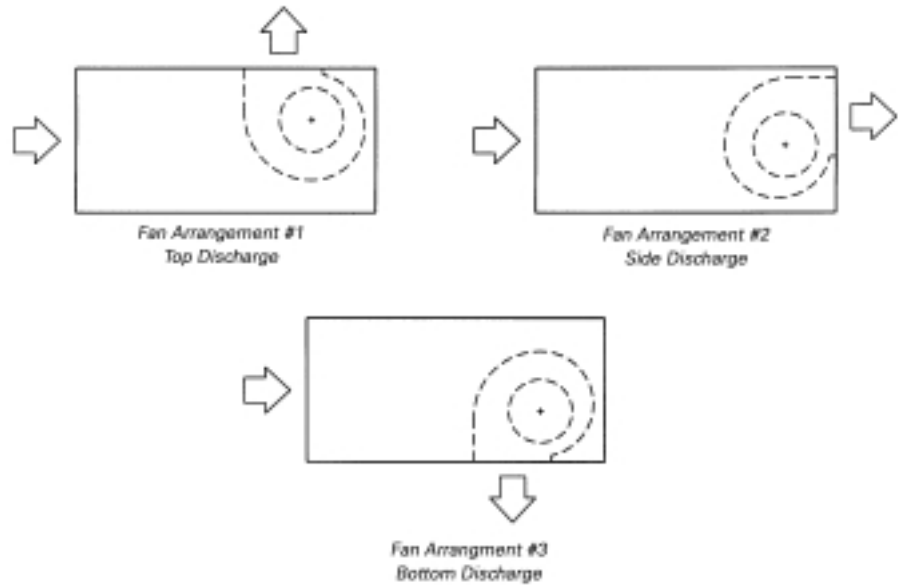

Vertical Configurations

For all arrangements shown, the gas piping and controls are on the near side. The electric control cabinet (EC) and disconnect are on the side opposite the air entering side. Selected vertical units are available with special options — steam and electric coils, no burner section.

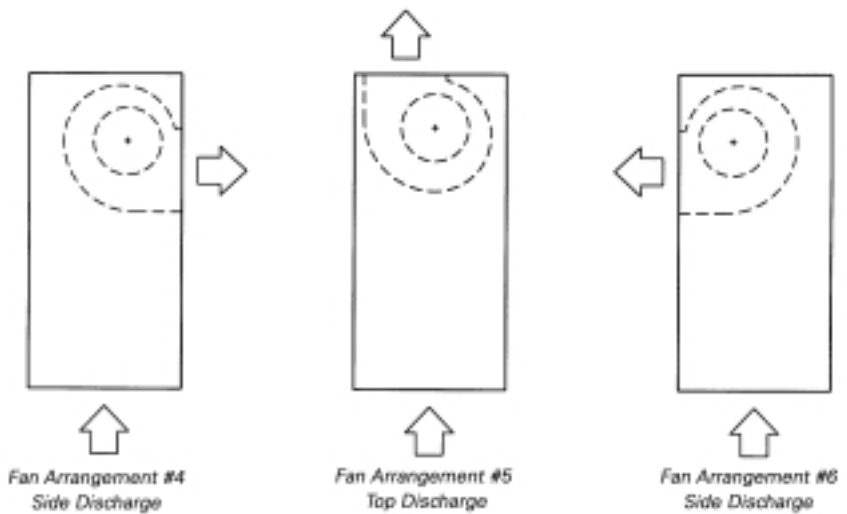



Application Considerations

Outdoor Units

Outdoor make-up air units are the most common approach to relieving negative pressure inside commercial and industrial facilities. All units offer the advantage of a full support system that is watertight, provides a plenum for return air, and has easily accessible piping and electrical connections.

The Need for Make-Up Air Units

When more air is exhausted from a building than is supplied by the mechanical systems, the building is under a "negative" condition. Air will leak into the building through cracks, windows, and doors. When a negative condition exists:

1

Flues and stacks may experience a backdraft and cause dangerous contaminants to remain in the occupied space. In the case of flues, the products of combustion may condense and corrode the equipment.

2

Under negative conditions, the exhaust system sees a greater static pressure. The capacity of each fan is reduced and this results in an inadequate removal of contaminants.

3

Drafts and cross-currents will increase in a negative condition, causing an uncomfortable or unhealthy work environment.

What Fuel to Use?

The most common fuel for heating make-up air is natural gas. This is because 100 percent of the energy goes into the air stream (92 percent sensible, 8 percent latent). Direct firing eliminates the need for heat exchangers or combustion chambers that can corrode or leak. Natural gas is often the least expensive fuel and is usually readily available.

Note: Selected horizontal and vertical units are available with special coil options (DX, chilled water, steam or electric).



Model Number Description

DFO A 109 A N C A 1 AA B 1 2 0 0 0 A
 1,2,3 4 5,6,7 8 9 10 11 12 13,14 15 16 17 18 19 20 21

Digits 1,2,3 — Unit Description

DFO = Direct Fired Outdoor Unit

Digit 4 — Development Sequence

A = First Generation

Digits 5,6,7 — Unit Size

109 = Unit Size 109
 112 = Unit Size 112
 115 = Unit Size 115
 118 = Unit Size 118
 215 = Unit Size 215
 218 = Unit Size 218
 220 = Unit Size 220
 222 = Unit Size 222
 225 = Unit Size 225
 230 = Unit Size 230
 SSS = Special Unit Size

Digit 8 — Main Power Supply

0 = No Selection
 A = 115/60/1
 B = 230/60/1
 C = 208/60/1
 D = 208/60/3
 E = 230/60/3
 F = 460/60/3
 S = Special

Digit 9 — Fuel

N = Natural Gas
 P = LP Gas (Propane)
 S = Special

Digit 10 — Design Sequence

C = Third Design

Digit 11 — Gas Control Option

A = Series 14 Constant Discharge Temperature
 B = Series 44 Space Temperature Control
 S = Special

Digit 12 — Type Gas Train Approvals

1 = Standard
 3 = IRI
 4 = FM
 S = Special

Digits 13,14 — Burner Input Rating (MBh)

AA = 275 MBh Input
 AB = 550 MBh Input
 AC = 825 MBh Input
 AD = 990 MBh Input
 AE = 1100 MBh Input

AF = 1375 MBh Input
 AG = 1650 MBh Input
 AH = 1925 MBh Input
 AJ = 2200 MBh Input
 AK = 2475 MBh Input
 AL = 2750 MBh Input
 AN = 3025 MBh Input
 AP = 3300 MBh Input
 AQ = 3575 MBh Input
 AR = 3850 MBh Input
 AT = 4125 MBh Input
 AV = 4400 MBh Input
 AW = 4675 MBh Input
 AX = 4950 MBh Input
 AY = 5225 MBh Input
 AZ = 5500 MBh Input
 A1 = 5775 MBh Input
 A2 = 6050 MBh Input
 A3 = 6325 MBh Input
 A4 = 6600 MBh Input
 A5 = 6875 MBh Input
 A6 = 7150 MBh Input
 A7 = 7425 MBh Input
 A8 = 7700 MBh Input
 A9 = 7975 MBh Input
 SS = Special

Digit 15 — Blower Motor HP

0 = No Selection
 B = ¾ HP Motor
 C = 1 HP Motor
 D = 1½ HP Motor
 E = 2 HP Motor
 F = 3 HP Motor
 G = 5 HP Motor
 H = 7½ HP Motor
 J = 10 HP Motor
 K = 15 HP Motor
 L = 20 HP Motor
 M = 25 HP Motor
 P = 30 HP Motor
 Q = 40 HP Motor
 R = 50 HP Motor
 T = 60 HP Motor
 S = Special

Digit 16 — Motor Speed and Starter

0 = No Selection
 1 = Single Speed ODP 1800 RPM
 2 = Single Speed TEFC 1800 RPM
 3 = Single Speed Energy Efficient ODP 1800 RPM
 4 = Single Speed Energy Efficient TEFC 1800 RPM
 5 = 2S1W ODP 1800/900 RPM
 6 = 2S2W ODP 1800/1200 RPM
 S = Special

Digit 17 — Fan Discharge*

Horizontal Arrangement

1 = Arrangement 1, Top
 2 = Arrangement 2, Side
 3 = Arrangement 3, Bottom
 *Select arrangements from page 6.

Vertical Arrangement

4 = Arrangement 4, Side
 5 = Arrangement 5, Top
 6 = Arrangement 6, Side
 *Select arrangements from page 6.

Digit 18 — Inlet Hood and Birdscreen

0 = None
 A = Inlet Hood and Birdscreen with Permanent Filters
 B = Inlet Hood and Birdscreen without Filters

Digit 19 — V-Bank Filter Section

0 = No Selection
 A = V-Bank Filter Section with Permanent Filters
 B = V-Bank Filter Section without Filters

Digit 20 — Dampers/Mixing Box

0 = No Selection
 A = Motorized RA Damper
 B = Motorized 75/25 Damper
 C = Mixing Box — Temperature Control
 D = Mixing Box — Building Pressure Control
 E = Mixing Box — Manual Control

Digit 21 — Miscellaneous Options

A = Controls Opposite from Standard
 B = Motorized Inlet Damper
 C = Motorized Outlet Damper
 D = Insulation on Basic Frame
 E = Insulation on Filter Section
 F = Internal Blower/Motor Isolation
 G = Extended Grease Lines
 H = Inlet On-Off Duct Stat
 K = 115V Duplex Service Receptacle with Power Transformer
 L = Circuit Analyzer
 M = Painted Basic Unit and Accessories
 N = UV Flame Sensor
 P = Clogged Filter Switch with Light
 Q = Exhaust Interlock
 R = Interlocking Relay
 T = City of Chicago Controls
 V = Omit Disconnect Switch
 W = High Gas Pressure Regulator 1-5 PSIG
 X = High Gas Pressure Regulator 5-10 PSIG
 Y = Adjustable Drive
 S = Special
 8 = Low Gas Pressure Burner



Performance Data

Table PD-1 — Direct-Fired Outdoor Unit

Models DFO	Blower Size	CFM STD Air @ 70	FPM Outlet Velocity	Total External Static Pressure (WC)								
				1/4"	3/8"	1/2"	3/4"	1"	1 1/4"	1 1/2"	2"	
109	1-9"	1600	1915	3/4	1	1	1	1	—	—	—	—
		1800	2155	1	1	1	1 1/2	1 1/2	1 1/2	—	—	
		2000	2390	1 1/2	1	1 1/2	1 1/2	1 1/2	2	2	—	
		2250	2690	1 1/2	1 1/2	1 1/2	2	2	2	2	3	
		2500	2990	2	2	2	2	2	3	3	3	
		2750	3290	2	2	2	3	3	3	3	3	
		3000	3585	3	3	3	3	3	3	5	5	
112	1-12"	3250	2180	1 1/2	2	2	2	3	3	3	3	
		3500	2360	2	2	2	3	3	3	3	5	
		3750	2540	2	2	3	3	3	3	3	5	
		4000	2720	3	3	3	3	3	3	5	5	
		4250	2900	3	3	3	3	3	5	5	5	
115	1-15"	4500	2190	2	2	3	3	3	3	5	—	
		5000	2430	3	3	3	3	3	5	5	5	
		5500	2670	3	3	3	5	5	5	5	5	
		6000	2910	5	5	5	5	5	5	7 1/2	—	
118	1-18"	6500	2215	3	5	5	5	5	5	5	7 1/2	
		7000	2390	5	5	5	5	5	5	7 1/2	7 1/2	
		7500	2565	5	5	5	5	5	7 1/2	7 1/2	7 1/2	
		8000	2740	5	5	5	7 1/2	7 1/2	7 1/2	7 1/2	7 1/2	
		8500	2915	5	5	7 1/2	7 1/2	7 1/2	7 1/2	7 1/2	10	
		9000	2190	5	5	5	5	7 1/2	—	—	—	
215	2-15"	9500	2310	5	5	5	5	7 1/2	7 1/2	—	—	
		10000	2430	5	5	5	7 1/2	7 1/2	7 1/2	7 1/2	—	
		10500	2550	5	5	7 1/2	7 1/2	7 1/2	7 1/2	7 1/2	—	
		11000	2670	7 1/2	7 1/2	7 1/2	7 1/2	7 1/2	7 1/2	10	10	
		11500	2790	7 1/2	7 1/2	7 1/2	7 1/2	7 1/2	10	10	10	
		12000	2910	7 1/2	7 1/2	7 1/2	7 1/2	10	10	10	15	
		12500	2125	7 1/2	7 1/2	7 1/2	7 1/2	7 1/2	—	—	—	
		13000	2215	7 1/2	7 1/2	7 1/2	7 1/2	10	10	—	—	
218	2-18"	14000	2390	7 1/2	7 1/2	7 1/2	10	10	10	15	—	
		15000	2565	7 1/2	10	10	10	10	15	15	15	
		16000	2740	10	10	10	10	15	15	15	15	
		17000	2915	10	10	10	15	15	15	15	20	
		18000	2140	7 1/2	10	10	10	15	15	15	—	
		19000	2260	10	10	10	10	15	15	15	—	
		20000	2380	10	10	10	15	15	15	15	20	
220	2-20"	21000	2500	10	15	15	15	15	15	20	20	
		22000	2620	15	15	15	15	15	20	20	20	
		23000	2740	15	15	15	15	15	20	20	20	
		24000	2860	15	15	15	15	20	20	20	25	
		25000	2980	15	15	15	20	20	20	20	25	
		26000	3100	15	20	20	20	20	20	25	25	
		25000	2450	15	15	15	15	20	20	20	25	
		26000	2550	15	15	15	20	20	20	20	25	
		27000	2650	15	15	15	20	20	20	20	25	
		28000	2750	15	20	20	20	20	25	25	30	
222	2-22"	29000	2850	20	20	20	20	25	25	25	30	
		30000	2950	20	20	20	20	25	25	25	30	
		31000	3050	20	20	20	25	25	25	30	30	
		30000	2235	15	15	15	15	20	20	—	—	
		32000	2385	15	15	15	20	20	20	25	—	
		34000	2535	15	20	20	20	20	25	25	30	
		36000	2685	20	20	20	20	25	25	30	30	
		38000	2835	20	20	20	25	25	30	30	40	
		40000	2985	20	25	25	25	30	30	30	40	
		42000	3135	25	25	25	30	30	40	40	40	
225	2-25"	44000	3285	25	30	30	30	40	40	40	40	
		46000	3430	30	30	30	40	40	40	40	50	
		44000	2365	20	20	20	25	25	30	—	—	
		48000	2580	20	25	25	25	30	30	40	—	
		52000	2800	25	25	30	30	40	40	40	50	
		56000	3020	30	30	30	40	40	40	40	50	
		60000	3240	40	40	40	40	40	50	50	50	
		64000	3440	40	40	40	50	50	50	50	60	

Notes:
 External Pressure Drop in inches of water. Add pressure drop of the optional accessories, if used, to the pressure drop of the duct work.
 Fresh Air Inlet Hood and Birdscreen .13" WC
 Fresh Air Inlet Hood With Filters .25" WC
 Motor Operated Inlet Damper .13" WC
 Motor Operated Discharge Damper .13" WC
 V-Bank Filter Section .25" WC
 Mixing Box .40" WC



Performance Data

Table PD-2 — Direct-Fired Outdoor Unit — Burner Selection (MBh Input)

Models	CFM Std Air 70 F	70 F Rise	80 F Rise	90 F Rise	100 F Rise	110 F Rise	120 F Rise
109	1600	131	150	169	188	207	225
	1800	148	169	190	211	232	254
	2000	164	188	211	235	258	282
	2250	185	211	238	264	291	317
	2500	205	235	264	293	323	352
	2750	226	258	291	323	355	387
112	3000	247	282	317	352	387	423
	3250	267	305	343	382	420	458
	3500	288	329	370	411	452	493
	3750	308	352	396	440	484	528
	4000	329	376	423	470	517	563
	4250	349	399	449	499	549	599
115	4500	370	423	475	528	581	634
	5000	411	470	528	587	646	704
	5500	452	517	581	646	710	775
	6000	493	563	634	704	775	845
	6500	534	610	687	763	839	916
	7000	575	657	740	822	904	986
118	7500	616	704	792	880	968	1057
	8000	657	751	845	939	1033	1127
	8500	698	798	898	998	1098	1197
	9000	740	845	951	1057	1162	1268
	9500	781	892	1004	1115	1227	1338
	10000	822	939	1057	1174	1291	1409
215	10500	863	986	1109	1233	1356	1479
	11000	904	1033	1162	1291	1420	1550
	11500	945	1080	1215	1350	1485	1620
	12000	986	1127	1268	1409	1550	1690
	12500	1027	1174	1321	1467	1614	1761
	13000	1068	1221	1373	1526	1679	1831
218	14000	1150	1315	1479	1643	1808	1972
	15000	1233	1409	1585	1761	1937	2113
	16000	1315	1503	1690	1878	2066	2254
	17000	1397	1597	1796	1996	2195	2395
	18000	1479	1690	1902	2113	2324	2536
	19000	1561	1784	2007	2230	2453	2677
220	20000	1643	1878	2113	2348	2583	2817
	21000	1726	1972	2219	2465	2712	2958
	22000	1808	2066	2324	2583	2841	3099
	23000	1890	2160	2430	2700	2970	3240
	24000	1972	2254	2536	2817	3099	3381
	25000	2054	2348	2641	2935	3228	3522
222	26000	2137	2442	2747	3052	3357	3663
	25000	2054	2348	2641	2935	3228	3522
	26000	2137	2442	2747	3052	3357	3663
	27000	2219	2536	2853	3170	3487	3803
	28000	2301	2630	2958	3287	3616	3944
	29000	2383	2723	3064	3404	3745	4085
225	30000	2465	2817	3170	3522	3874	4226
	31000	2547	2911	3275	3639	4003	4367
	30000	2465	2817	3170	3522	3874	4226
	32000	2630	3005	3381	3757	4132	4508
	34000	2794	3193	3592	3991	4390	4790
	36000	2958	3381	3803	4226	4649	5071
230	38000	3123	3569	4015	4461	4907	5353
	40000	3287	3757	4226	4696	5165	5635
	42000	3451	3944	4437	4930	5423	5917
	44000	3616	4132	4649	5165	5682	6198
	46000	3780	4320	4860	5400	5940	6480
	48000	3944	4508	5071	5635	6198	6762
230	52000	4273	4883	5494	6104	6715	7325
	56000	4602	5259	5917	6574	7231	—
	60000	4930	5635	6339	7043	7748	—
	64000	5259	6010	6762	7513	—	—

Notes:

1. Determine the temperature rise required through the heater by subtracting winter design temperature from the desired indoor temperature.

2. Select burner required:
 $BTUH = \frac{CFM \times \Delta T \times 1.08}{.92}$

Formula includes 1.08 constant for heat content of air and .92 factor which is an average ratio of net and gross heating values of common fuel gases. (.92% sensible, 8% latent).

3. Contact Diversified Commercial Products Technical Support on temperature rise requirements greater than 120 F.

Gas Piping

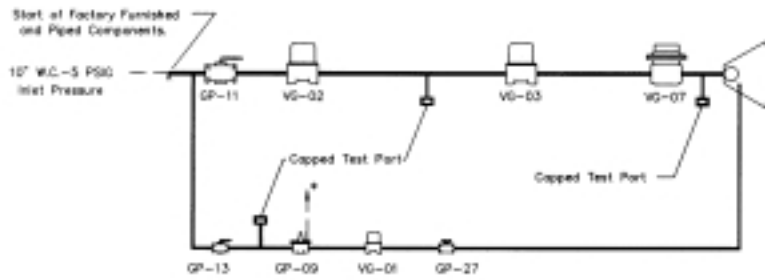

Standard

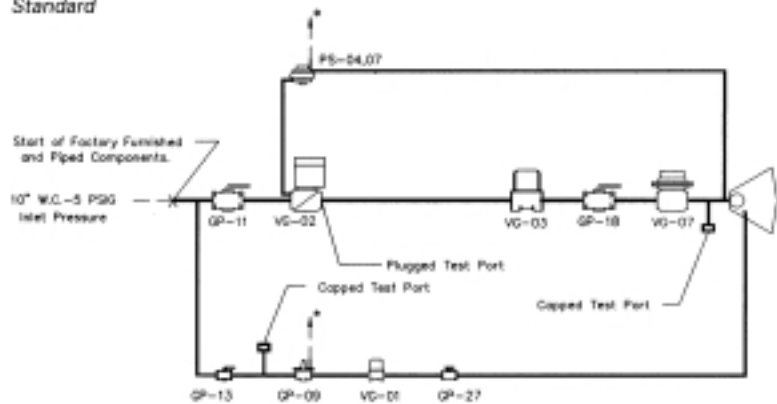

FM

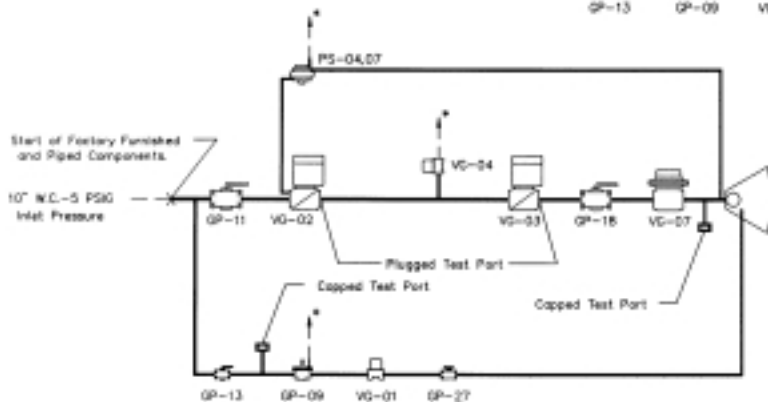

JRI*

Component Identification

GP-09	Pilot Gas Pressure Regulator
GP-11	Main Gas Shutoff Valve
GP-13	Pilot Gas Shutoff Valve
GP-17	Auxiliary Gas Shutoff Valve
GP-18	Auxiliary Gas Shutoff Valve
GP-27	Orificed Needle Valve
VG-01	Pilot Gas Valve
VG-02	Main Gas Valve
VG-03	Auxiliary Gas Valve
VG-04	N/O Vent Valve
VG-07	Maxitrol Modulating Valve
PS-04	Low Gas Pressure Switch
PS-07	High Gas Pressure Switch

Notes:

- 1 Vents to outside furnished by factory on outdoor units.
- 2 Under 825 MBh will require an additional gas pressure regulator if inlet pressure exceeds 1 psig.
- 3 4400 MBh and above will require a minimum inlet pressure of 1 psig. For inlet pressure under 1 psig, contact factory.

4

For inlet pressure under 10" WC, contact factory.

5

Contact factory for manifold required for CGA.

*Items PS-04, PS-07, VG-04 and GP-18 are not required to meet IRI requirements if the unit is ETL approved. Refer to page 40.



Gas Piping

Table GP-1— Gas Pressure Regulator Selection

If Burner Size (BS) Is:	And Gas Pressure (GP) Is:	Then:
BS ≤ 825	GP < 7" WC	Call factory to verify availability and pricing
	7" WC ≤ GP < 10" WC	Use low gas pressure burner
	10" WC ≤ GP < 1 PSI	No low gas pressure burner or high gas pressure regulator required
	1 PSI ≤ GP ≤ 5 PSI	Use high gas pressure regulator 1-5 PSI
	5 PSI < GP ≤ 10 PSI	Use high gas pressure regulator 5-10 PSI
	10 PSI < GP ≤ 50 PSI	Use high gas pressure regulator over 10 PSI
990 ≤ BS ≤ 4125	50 PSI < GP	Call factory to verify availability and pricing
	GP < 7" WC	Call factory to verify availability and pricing
	7" WC ≤ GP < 10" WC	Use low gas pressure burner
	10" WC ≤ GP ≤ 5 PSI	No low gas pressure burner or high gas pressure regulator required
	5 PSI < GP ≤ 10 PSI	Use high gas pressure regulator 5-10 PSI
4400 ≤ BS ≤ 7975	10 PSI < GP ≤ 50 PSI	Use high gas pressure regulator over 10 PSI
	50 PSI < GP	Call factory to verify availability and pricing
	GP < 1 PSI	Call factory to verify availability and pricing
	1 PSI ≤ GP ≤ 5 PSI	No low gas pressure burner or high gas pressure regulator required
	5 PSI < GP ≤ 10 PSI	Use high gas pressure regulator 5-10 PSI
	10 PSI < GP ≤ 50 PSI	Use high gas pressure regulator over 10 PSI
	50 PSI < GP	Call factory to verify availability and pricing



Gas Piping

Table GP-2 — Gas Pipe Connection Size — Direct-Fired Units — IRI Gas Train — R/A Meeting ETL

MBH	Inlet Gas Pressure (inches of water column)									
	6-7"	8-11"	12-14"	15-20"	21-27"	1 psi	2 psi	3 psi	4 psi	5 psi
275	1"	3/4"	3/4"	3/4"	3/4"	3/4"	3/4"	3/4"	3/4"	3/4"
550	1 1/4"	1"	3/4"	3/4"	3/4"	3/4"	3/4"	3/4"	3/4"	3/4"
825	2"	1 1/4"	1 1/4"	1 1/4"	1 1/4"	1 1/4"	1 1/4"	1 1/4"	1 1/4"	1 1/4"
1,100	2"	1 1/4"	1 1/4"	1 1/4"	1 1/4"	1 1/4"	1 1/4"	1 1/4"	1 1/4"	1 1/4"
1,375	2"	1 1/2"	1 1/4"	1 1/4"	1 1/4"	1 1/4"	1 1/4"	1 1/4"	1 1/4"	1 1/4"
1,650	N/A	1 1/2"	1 1/4"	1 1/4"	1 1/4"	1 1/4"	1 1/4"	1 1/4"	1 1/4"	1 1/4"
1,925	N/A	2"	1 1/2"	1 1/4"	1 1/4"	1 1/4"	1 1/4"	1 1/4"	1 1/4"	1 1/4"
2,200	N/A	2"	1 1/2"	1 1/4"	1 1/4"	1 1/4"	1 1/4"	1 1/4"	1 1/4"	1 1/4"
2,475	2 1/2"	2"	2"	1 1/2"	1 1/4"	1 1/4"	1 1/4"	1 1/4"	1 1/4"	1 1/4"
2,750	3"	2"	2"	1 1/2"	1 1/4"	1 1/4"	1 1/4"	1 1/4"	1 1/4"	1 1/4"
3,025	3"	2 1/2"	2"	2"	1 1/2"	1 1/4"	1 1/4"	1 1/4"	1 1/4"	1 1/4"
3,300	N/A	2 1/2"	2"	2"	2"	2"	2"	2"	2"	2"
3,575	N/A	2 1/2"	2"	2"	2"	2"	2"	2"	2"	2"
3,850	N/A	2 1/2"	2"	2"	2"	2"	2"	2"	2"	2"
4,125	N/A	2 1/2"	2"	2"	2"	2"	2"	2"	2"	2"
4,400	N/A	2 1/2"	2"	2"	2"	2"	2"	2"	2"	2"
4,675	N/A	3"	2 1/2"	2"	2"	2"	2"	2"	2"	2"
4,950	N/A	3"	2 1/2"	2"	2"	2"	2"	2"	2"	2"
5,225	N/A	3"	2 1/2"	2"	2"	2"	2"	2"	2"	2"
5,500	N/A	3"	2 1/2"	2 1/2"	2"	2 1/2"	2 1/2"	2 1/2"	2 1/2"	2 1/2"
5,775	N/A	N/A	2 1/2"	2 1/2"	2 1/2"	2 1/2"	2 1/2"	2 1/2"	2 1/2"	2 1/2"
6,050	N/A	N/A	2 1/2"	2 1/2"	2 1/2"	2 1/2"	2 1/2"	2 1/2"	2 1/2"	2 1/2"
6,325	N/A	N/A	2 1/2"	2 1/2"	2 1/2"	2 1/2"	2 1/2"	2 1/2"	2 1/2"	2 1/2"
6,600	N/A	N/A	2 1/2"	2 1/2"	2 1/2"	2 1/2"	2 1/2"	2 1/2"	2 1/2"	2 1/2"
6,875	N/A	N/A	2 1/2"	2 1/2"	2 1/2"	2 1/2"	2 1/2"	2 1/2"	2 1/2"	2 1/2"
7,150	N/A	N/A	3"	2 1/2"	2 1/2"	2 1/2"	2 1/2"	2 1/2"	2 1/2"	2 1/2"
7,700	N/A	N/A	3"	2 1/2"	2 1/2"	3"	3"	3"	3"	3"
8,250	N/A	N/A	3"	3"	2 1/2"	3"	3"	3"	3"	3"
8,800	N/A	N/A	N/A	3"	3"	3"	3"	3"	3"	3"
9,350	N/A	N/A	N/A	3"	3"	3"	3"	3"	3"	3"
9,900	N/A	N/A	N/A	3"	3"	3"	3"	3"	3"	3"
10,450	N/A	N/A	N/A	N/A	N/A	N/A	N/A	N/A	N/A	N/A
11,000	N/A	N/A	N/A	N/A	N/A	N/A	N/A	N/A	N/A	N/A
11,550	N/A	N/A	N/A	N/A	N/A	N/A	N/A	N/A	N/A	N/A

Table GP-3 — Gas Pipe Connection Size — Direct-Fired Units — FM Gas Train — R/A Meeting ETL

MBH	Inlet Gas Pressure (inches of water column)									
	6-7"	8-11"	12-14"	15-20"	21-27"	1 psi	2 psi	3 psi	4 psi	5 psi
275	1"	3/4"	3/4"	3/4"	3/4"	3/4"	3/4"	3/4"	3/4"	3/4"
550	1 1/4"	1"	3/4"	3/4"	3/4"	3/4"	3/4"	3/4"	3/4"	3/4"
825	1 1/2"	1 1/4"	1 1/4"	1 1/4"	1 1/4"	1 1/4"	1 1/4"	1 1/4"	1 1/4"	1 1/4"
1,100	2"	1 1/4"	1 1/4"	1 1/4"	1 1/4"	1 1/4"	1 1/4"	1 1/4"	1 1/4"	1 1/4"
1,375	2"	1 1/2"	1 1/2"	1 1/2"	1 1/2"	1 1/4"	1 1/4"	1 1/4"	1 1/4"	1 1/4"
1,650	2"	1 1/2"	1 1/4"	1 1/4"	1 1/4"	1 1/4"	1 1/4"	1 1/4"	1 1/4"	1 1/4"
1,925	2"	2"	1 1/4"	1 1/4"	1 1/4"	1 1/4"	1 1/4"	1 1/4"	1 1/4"	1 1/4"
2,200	N/A	2"	1 1/2"	1 1/4"	1 1/4"	1 1/4"	1 1/4"	1 1/4"	1 1/4"	1 1/4"
2,475	N/A	2"	1 1/2"	1 1/4"	1 1/4"	1 1/4"	1 1/4"	1 1/4"	1 1/4"	1 1/4"
2,750	N/A	2"	2"	1 1/2"	1 1/4"	1 1/4"	1 1/4"	1 1/4"	1 1/4"	1 1/4"
3,025	N/A	2"	2"	1 1/2"	1 1/4"	1 1/4"	1 1/4"	1 1/4"	1 1/4"	1 1/4"
3,300	N/A	2 1/2"	2"	2"	2"	2"	2"	2"	2"	2"
3,575	N/A	3"	2"	2"	2"	2"	2"	2"	2"	2"
3,850	N/A	3"	2"	2"	2"	2"	2"	2"	2"	2"
4,125	N/A	3"	2"	2"	2"	2"	2"	2"	2"	2"
4,400	N/A	3"	2"	2"	2"	2"	2"	2"	2"	2"
4,675	N/A	3"	2"	2"	2"	2"	2"	2"	2"	2"
4,950	N/A	3"	2 1/2"	2 1/2"	2 1/2"	2 1/2"	2 1/2"	2 1/2"	2 1/2"	2 1/2"
5,225	N/A	3"	2 1/2"	2 1/2"	2 1/2"	2 1/2"	2 1/2"	2 1/2"	2 1/2"	2 1/2"
5,500	N/A	3"	2 1/2"	2 1/2"	2 1/2"	2 1/2"	2 1/2"	2 1/2"	2 1/2"	2 1/2"
5,775	N/A	N/A	2 1/2"	2 1/2"	2 1/2"	2 1/2"	2 1/2"	2 1/2"	2 1/2"	2 1/2"
6,050	N/A	N/A	2 1/2"	2 1/2"	2 1/2"	2 1/2"	2 1/2"	2 1/2"	2 1/2"	2 1/2"
6,325	N/A	N/A	2 1/2"	2 1/2"	2 1/2"	2 1/2"	2 1/2"	2 1/2"	2 1/2"	2 1/2"
6,600	N/A	N/A	2 1/2"	2 1/2"	2 1/2"	2 1/2"	2 1/2"	2 1/2"	2 1/2"	2 1/2"
6,875	N/A	N/A	3"	2 1/2"	2 1/2"	2 1/2"	2 1/2"	2 1/2"	2 1/2"	2 1/2"
7,150	N/A	N/A	3"	2 1/2"	2 1/2"	2 1/2"	2 1/2"	2 1/2"	2 1/2"	2 1/2"
7,700	N/A	N/A	3"	3"	2 1/2"	2 1/2"	2 1/2"	2 1/2"	2 1/2"	2 1/2"
8,250	N/A	N/A	3"	3"	3"	3"	3"	3"	3"	3"
8,800	N/A	N/A	N/A	3"	3"	3"	3"	3"	3"	3"
9,350	N/A	N/A	N/A	3"	3"	3"	3"	3"	3"	3"
9,900	N/A	N/A	N/A	3"	3"	3"	3"	3"	3"	3"
10,450	N/A	N/A	N/A	N/A	N/A	N/A	N/A	N/A	N/A	N/A
11,000	N/A	N/A	N/A	N/A	N/A	N/A	N/A	N/A	N/A	N/A
11,550	N/A	N/A	N/A	N/A	N/A	N/A	N/A	N/A	N/A	N/A



Gas Piping

Table GP-4 — Gas Pipe Connection Size — Direct-Fired Units — Standard Gas Train — R/A Meeting ETL

MBH	Inlet Gas Pressure (inches of water column)									
	6-7"	8-11"	12-14"	15-20"	21-27"	1 psi	2 psi	3 psi	4 psi	5 psi
275	1"	3/4"	3/4"	3/4"	3/4"	3/4"	3/4"	3/4"	3/4"	3/4"
550	1 1/4"	1"	3/4"	3/4"	3/4"	3/4"	3/4"	3/4"	3/4"	3/4"
825	1 1/2"	1 1/4"	1 1/4"	1 1/4"	1 1/4"	1 1/4"	1 1/4"	1 1/4"	1 1/4"	1 1/4"
1,100	2"	1 1/4"	1 1/4"	1 1/4"	1 1/4"	1 1/4"	1 1/4"	1 1/4"	1 1/4"	1 1/4"
1,375	2"	1 1/2"	1 1/4"	1 1/4"	1 1/4"	1 1/4"	1 1/4"	1 1/4"	1 1/4"	1 1/4"
1,650	2"	1 1/2"	1 1/4"	1 1/4"	1 1/4"	1 1/4"	1 1/4"	1 1/4"	1 1/4"	1 1/4"
1,925	2 1/2"	2"	1 1/4"	1 1/4"	1 1/4"	1 1/4"	1 1/4"	1 1/4"	1 1/4"	1 1/4"
2,200	2 1/2"	2"	1 1/2"	1 1/4"	1 1/4"	1 1/4"	1 1/4"	1 1/4"	1 1/4"	1 1/4"
2,475	2 1/2"	2"	1 1/2"	1 1/4"	1 1/4"	1 1/4"	1 1/4"	1 1/4"	1 1/4"	1 1/4"
2,750	2 1/2"	2"	2"	1 1/2"	1 1/4"	1 1/4"	1 1/4"	1 1/4"	1 1/4"	1 1/4"
3,025	2 1/2"	2"	2"	1 1/2"	1 1/4"	1 1/4"	1 1/4"	1 1/4"	1 1/4"	1 1/4"
3,300	2 1/2"	2"	2"	2"	2"	2"	2"	2"	2"	2"
3,575	3"	2 1/2"	2"	2"	2"	2"	2"	2"	2"	2"
3,850	3"	2 1/2"	2"	2"	2"	2"	2"	2"	2"	2"
4,125	N/A	2 1/2"	2"	2"	2"	2"	2"	2"	2"	2"
4,400	N/A	2 1/2"	2"	2"	2"	2"	2"	2"	2"	2"
4,675	N/A	2 1/2"	2"	2"	2"	2"	2"	2"	2"	2"
4,950	N/A	2 1/2"	2"	2"	2"	2"	2"	2"	2"	2"
5,225	N/A	2 1/2"	2 1/2"	2"	2"	2"	2"	2"	2"	2"
5,500	N/A	2 1/2"	2 1/2"	2"	2"	2"	2"	2"	2"	2"
5,775	N/A	2 1/2"	2 1/2"	2 1/2"	2 1/2"	2 1/2"	2 1/2"	2 1/2"	2 1/2"	2 1/2"
6,050	N/A	3	2 1/2"	2 1/2"	2 1/2"	2 1/2"	2 1/2"	2 1/2"	2 1/2"	2 1/2"
6,325	N/A	3	2 1/2"	2 1/2"	2 1/2"	2 1/2"	2 1/2"	2 1/2"	2 1/2"	2 1/2"
6,600	N/A	3	2 1/2"	2 1/2"	2 1/2"	2 1/2"	2 1/2"	2 1/2"	2 1/2"	2 1/2"
6,875	N/A	3	2 1/2"	2 1/2"	2 1/2"	2 1/2"	2 1/2"	2 1/2"	2 1/2"	2 1/2"
7,150	N/A	N/A	2 1/2"	2 1/2"	2 1/2"	2 1/2"	2 1/2"	2 1/2"	2 1/2"	2 1/2"
7,700	N/A	N/A	2 1/2"	2 1/2"	2 1/2"	2 1/2"	2 1/2"	2 1/2"	2 1/2"	2 1/2"
8,250	N/A	N/A	2 1/2"	2 1/2"	2 1/2"	2 1/2"	2 1/2"	2 1/2"	2 1/2"	2 1/2"
8,800	N/A	N/A	3	3	3	3	3	3	3	3
9,350	N/A	N/A	3	3	3	3	3	3	3	3
9,900	N/A	N/A	3	3	3	3	3	3	3	3
10,450	N/A	N/A	N/A	N/A	N/A	N/A	N/A	N/A	N/A	N/A
11,000	N/A	N/A	N/A	N/A	N/A	N/A	N/A	N/A	N/A	N/A
11,550	N/A	N/A	N/A	N/A	N/A	N/A	N/A	N/A	N/A	N/A

Table GP-5 — Gas Pipe Connection Size — Direct-Fired Units — IRI Gas Train — 100% OA or R/A Not ETL

MBH	Inlet Gas Pressure (inches of water column)									
	6-7"	8-11"	12-14"	15-20"	21-27"	1 psi	2 psi	3 psi	4 psi	5 psi
275	1 1/4"	3/4"	3/4"	3/4"	3/4"	3/4"	3/4"	3/4"	3/4"	3/4"
550	N/A	1"	3/4"	3/4"	3/4"	3/4"	3/4"	3/4"	3/4"	3/4"
825	N/A	N/A	1"	3/4"	3/4"	3/4"	3/4"	3/4"	3/4"	3/4"
1,100	N/A	1 1/2"	1 1/4"	1 1/4"	1 1/4"	1 1/4"	1 1/4"	1 1/4"	1 1/4"	1 1/4"
1,375	N/A	2"	1 1/4"	1 1/4"	1 1/4"	1 1/4"	1 1/4"	1 1/4"	1 1/4"	1 1/4"
1,650	N/A	N/A	1 1/2"	1 1/4"	1 1/4"	1 1/4"	1 1/4"	1 1/4"	1 1/4"	1 1/4"
1,925	N/A	N/A	2"	1 1/2"	1 1/4"	1 1/4"	1 1/4"	1 1/4"	1 1/4"	1 1/4"
2,200	N/A	N/A	2"	1 1/2"	1 1/4"	1 1/4"	1 1/4"	1 1/4"	1 1/4"	1 1/4"
2,475	N/A	N/A	2"	2"	1 1/2"	1 1/4"	1 1/4"	1 1/4"	1 1/4"	1 1/4"
2,750	N/A	N/A	2"	2"	1 1/2"	1 1/4"	1 1/4"	1 1/4"	1 1/4"	1 1/4"
3,025	N/A	N/A	2"	2"	2"	2"	2"	2"	2"	2"
3,300	N/A	N/A	2"	2"	2"	2"	2"	2"	2"	2"
3,575	N/A	N/A	2 1/2"	2"	2"	2"	2"	2"	2"	2"
3,850	N/A	N/A	2 1/2"	2"	2"	2"	2"	2"	2"	2"
4,125	N/A	N/A	2 1/2"	2"	2"	2"	2"	2"	2"	2"
4,400	N/A	N/A	2 1/2"	2 1/2"	2"	2"	2"	2"	2"	2"
4,675	N/A	N/A	2 1/2"	2 1/2"	2"	2"	2"	2"	2"	2"
4,950	N/A	N/A	2 1/2"	2 1/2"	2"	2"	2"	2"	2"	2"
5,225	N/A	N/A	3"	2 1/2"	2"	2"	2"	2"	2"	2"
5,500	N/A	N/A	3"	2 1/2"	2 1/2"	2"	2"	2"	2"	2"
5,775	N/A	N/A	3"	2 1/2"	2 1/2"	2"	2"	2"	2"	2"
6,050	N/A	N/A	3"	2 1/2"	2 1/2"	2 1/2"	2 1/2"	2 1/2"	2 1/2"	2 1/2"
6,325	N/A	N/A	N/A	2 1/2"	2 1/2"	2 1/2"	2 1/2"	2 1/2"	2 1/2"	2 1/2"
6,600	N/A	N/A	N/A	3"	2 1/2"	2 1/2"	2 1/2"	2 1/2"	2 1/2"	2 1/2"
6,875	N/A	N/A	N/A	3"	2 1/2"	2 1/2"	2 1/2"	2 1/2"	2 1/2"	2 1/2"
7,150	N/A	N/A	N/A	3"	2 1/2"	2 1/2"	2 1/2"	2 1/2"	2 1/2"	2 1/2"
7,700	N/A	N/A	N/A	3"	2 1/2"	2 1/2"	2 1/2"	2 1/2"	2 1/2"	2 1/2"
8,250	N/A	N/A	N/A	N/A	2 1/2"	2 1/2"	2 1/2"	2 1/2"	2 1/2"	2 1/2"
8,800	N/A	N/A	N/A	N/A	3"	2 1/2"	2 1/2"	2 1/2"	2 1/2"	2 1/2"
9,350	N/A	N/A	N/A	N/A	3"	3"	3"	3"	3"	3"
9,900	N/A	N/A	N/A	N/A	3"	3"	3"	3"	3"	3"
10,450	N/A	N/A	N/A	N/A	N/A	N/A	N/A	N/A	N/A	N/A
11,000	N/A	N/A	N/A	N/A	N/A	N/A	N/A	N/A	N/A	N/A
11,550	N/A	N/A	N/A	N/A	N/A	N/A	N/A	N/A	N/A	N/A
12,100	N/A	N/A	N/A	N/A	N/A	N/A	N/A	N/A	N/A	N/A



Gas Piping

Table GP-6 — Gas Pipe Connection Size— Direct-Fired Units — FM Gas Train — 100% OA or R/A Not ETL

MBH	Inlet Gas Pressure (inches of water column)									
	6-7"	8-11"	12-14"	15-20"	21-27"	1 psi	2 psi	3 psi	4 psi	5 psi
275	1 1/4"	3/4"	3/4"	3/4"	3/4"	3/4"	3/4"	3/4"	3/4"	3/4"
550	N/A	1"	3/4"	3/4"	3/4"	3/4"	3/4"	3/4"	3/4"	3/4"
825	N/A	1 1/4"	1"	1"	3/4"	3/4"	3/4"	3/4"	3/4"	3/4"
1,100	N/A	2"	1 1/4"	1 1/4"	1 1/4"	1 1/4"	1 1/4"	1 1/4"	1 1/4"	1 1/4"
1,375	N/A	2"	1 1/4"	1 1/4"	1 1/4"	1 1/4"	1 1/4"	1 1/4"	1 1/4"	1 1/4"
1,650	N/A	2"	1 1/4"	1 1/4"	1 1/4"	1 1/4"	1 1/4"	1 1/4"	1 1/4"	1 1/4"
1,925	N/A	2"	1 1/2"	1 1/2"	1 1/4"	1 1/4"	1 1/4"	1 1/4"	1 1/4"	1 1/4"
2,200	N/A	N/A	2"	1 1/2"	1 1/4"	1 1/4"	1 1/4"	1 1/4"	1 1/4"	1 1/4"
2,475	N/A	N/A	2"	1 1/2"	1 1/4"	1 1/4"	1 1/4"	1 1/4"	1 1/4"	1 1/4"
2,750	N/A	N/A	2"	2"	2"	1 1/2"	1 1/2"	1 1/2"	1 1/2"	1 1/2"
3,025	N/A	N/A	2"	2"	2"	2"	2"	2"	2"	2"
3,300	N/A	N/A	2"	2"	2"	2"	2"	2"	2"	2"
3,575	N/A	N/A	2"	2"	2"	2"	2"	2"	2"	2"
3,850	N/A	N/A	2"	2"	2"	2"	2"	2"	2"	2"
4,125	N/A	N/A	2 1/2"	2"	2"	2"	2"	2"	2"	2"
4,400	N/A	N/A	3"	2"	2"	2"	2"	2"	2"	2"
4,675	N/A	N/A	3"	2 1/2"	2"	2"	2"	2"	2"	2"
4,950	N/A	N/A	3"	2 1/2"	2"	2"	2"	2"	2"	2"
5,225	N/A	N/A	3"	2 1/2"	2 1/2"	2 1/2"	2 1/2"	2 1/2"	2 1/2"	2 1/2"
5,500	N/A	N/A	3"	2 1/2"	2 1/2"	2 1/2"	2 1/2"	2 1/2"	2 1/2"	2 1/2"
5,775	N/A	N/A	3"	2 1/2"	2 1/2"	2 1/2"	2 1/2"	2 1/2"	2 1/2"	2 1/2"
6,050	N/A	N/A	3"	2 1/2"	2 1/2"	2 1/2"	2 1/2"	2 1/2"	2 1/2"	2 1/2"
6,325	N/A	N/A	N/A	2 1/2"	2 1/2"	2 1/2"	2 1/2"	2 1/2"	2 1/2"	2 1/2"
6,600	N/A	N/A	N/A	3"	2 1/2"	2 1/2"	2 1/2"	2 1/2"	2 1/2"	2 1/2"
6,875	N/A	N/A	N/A	3"	2 1/2"	2 1/2"	2 1/2"	2 1/2"	2 1/2"	2 1/2"
7,150	N/A	N/A	N/A	3"	2 1/2"	2 1/2"	2 1/2"	2 1/2"	2 1/2"	2 1/2"
7,700	N/A	N/A	N/A	3"	2 1/2"	2 1/2"	2 1/2"	2 1/2"	2 1/2"	2 1/2"
8,250	N/A	N/A	N/A	N/A	2 1/2"	2 1/2"	2 1/2"	2 1/2"	2 1/2"	2 1/2"
8,800	N/A	N/A	N/A	N/A	3"	2 1/2"	2 1/2"	2 1/2"	2 1/2"	2 1/2"
9,350	N/A	N/A	N/A	N/A	3"	3"	3"	3"	3"	3"
9,900	N/A	N/A	N/A	N/A	3"	3"	3"	3"	3"	3"
10,450	N/A	N/A	N/A	N/A	3"	3"	3"	3"	3"	3"
11,000	N/A	N/A	N/A	N/A	N/A	3"	3"	3"	3"	3"
11,550	N/A	N/A	N/A	N/A	N/A	CF	CF	CF	CF	CF
12,100	N/A	N/A	N/A	N/A	N/A	CF	CF	CF	CF	CF

Note:
CF = Contact Factory

Table GP-7 — Gas Pipe Connection Size— Direct-Fired Units — Standard Gas Train — 100% OA or R/A Not ETL

MBH	Inlet Gas Pressure (inches of water column)									
	6-7"	8-11"	12-14"	15-20"	21-27"	1 psi	2 psi	3 psi	4 psi	5 psi
275	1 1/4"	3/4"	3/4"	3/4"	3/4"	3/4"	3/4"	3/4"	3/4"	3/4"
550	1 1/4"	1"	3/4"	3/4"	3/4"	3/4"	3/4"	3/4"	3/4"	3/4"
825	N/A	N/A	1"	1"	3/4"	3/4"	3/4"	3/4"	3/4"	3/4"
1,100	N/A	2"	1 1/4"	1 1/4"	1 1/4"	1 1/4"	1 1/4"	1 1/4"	1 1/4"	1 1/4"
1,375	N/A	2"	1 1/4"	1 1/4"	1 1/4"	1 1/4"	1 1/4"	1 1/4"	1 1/4"	1 1/4"
1,650	N/A	2"	1 1/4"	1 1/4"	1 1/4"	1 1/4"	1 1/4"	1 1/4"	1 1/4"	1 1/4"
1,925	N/A	N/A	1 1/2"	1 1/2"	1 1/4"	1 1/4"	1 1/4"	1 1/4"	1 1/4"	1 1/4"
2,200	N/A	2 1/2"	2"	1 1/2"	1 1/4"	1 1/4"	1 1/4"	1 1/4"	1 1/4"	1 1/4"
2,475	N/A	2 1/2"	2"	1 1/2"	1 1/4"	1 1/4"	1 1/4"	1 1/4"	1 1/4"	1 1/4"
2,750	N/A	2 1/2"	2"	1 1/2"	1 1/4"	1 1/4"	1 1/4"	1 1/4"	1 1/4"	1 1/4"
3,025	N/A	2 1/2"	2"	2"	2"	2"	2"	2"	2"	2"
3,300	N/A	3"	2"	2"	2"	2"	2"	2"	2"	2"
3,575	N/A	3"	2"	2"	2"	2"	2"	2"	2"	2"
3,850	N/A	N/A	2"	2"	2"	2"	2"	2"	2"	2"
4,125	N/A	N/A	2 1/2"	2"	2"	2"	2"	2"	2"	2"
4,400	N/A	N/A	2 1/2"	2"	2"	2"	2"	2"	2"	2"
4,675	N/A	N/A	2 1/2"	2"	2"	2"	2"	2"	2"	2"
4,950	N/A	N/A	2 1/2"	2 1/2"	2"	2"	2"	2"	2"	2"
5,225	N/A	N/A	2 1/2"	2 1/2"	2"	2"	2"	2"	2"	2"
5,500	N/A	N/A	2 1/2"	2 1/2"	2"	2"	2"	2"	2"	2"
5,775	N/A	N/A	2 1/2"	2 1/2"	2"	2"	2"	2"	2"	2"
6,050	N/A	N/A	2 1/2"	2 1/2"	2 1/2"	2 1/2"	2 1/2"	2 1/2"	2 1/2"	2 1/2"
6,325	N/A	N/A	2 1/2"	2 1/2"	2 1/2"	2 1/2"	2 1/2"	2 1/2"	2 1/2"	2 1/2"
6,600	N/A	N/A	2 1/2"	2 1/2"	2 1/2"	2 1/2"	2 1/2"	2 1/2"	2 1/2"	2 1/2"
6,875	N/A	N/A	3"	2 1/2"	2 1/2"	2 1/2"	2 1/2"	2 1/2"	2 1/2"	2 1/2"
7,150	N/A	N/A	3"	2 1/2"	2 1/2"	2 1/2"	2 1/2"	2 1/2"	2 1/2"	2 1/2"
7,700	N/A	N/A	3"	2 1/2"	2 1/2"	2 1/2"	2 1/2"	2 1/2"	2 1/2"	2 1/2"
8,250	N/A	N/A	N/A	3"	2 1/2"	2 1/2"	2 1/2"	2 1/2"	2 1/2"	2 1/2"
8,800	N/A	N/A	N/A	3"	2 1/2"	2 1/2"	2 1/2"	2 1/2"	2 1/2"	2 1/2"
9,350	N/A	N/A	N/A	3"	3"	3"	3"	3"	3"	3"
9,900	N/A	N/A	N/A	N/A	3"	3"	3"	3"	3"	3"
10,450	N/A	N/A	N/A	N/A	3"	3"	3"	3"	3"	3"
11,000	N/A	N/A	N/A	N/A	3"	3"	3"	3"	3"	3"
11,550	N/A	N/A	N/A	N/A	N/A	CF	CF	CF	CF	CF
12,100	N/A	N/A	N/A	N/A	N/A	CF	CF	CF	CF	CF

Note:
CF=Contact Factory

Controls

System 14 — Constant Discharge Air Temperatures

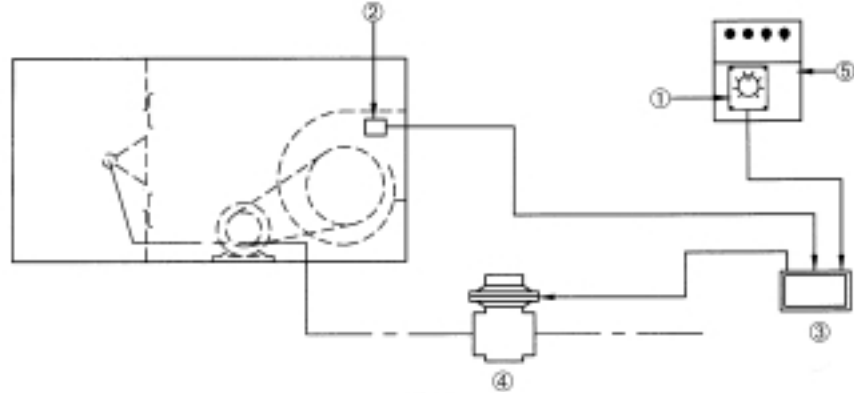

①



②



③



④



⑤

Optional

Component Description

- 1 Remote Temperature Selector
Not temperature sensitive. Mounted on remote control station.
- 2 Air Sensor
Installed in blower discharge.
- 3 Amplifier
Installed in electrical control panel. Contains wiring terminals, sensitivity adjustments and one calibrating potentiometer.
- 4 Modulator/Regulator Valve
Mounted in gas piping manifold. Receives electrical signal from amplifier and adjusts gas pressure to maintain desired temperature.
- 5 Remote Control Station
Optional

System 14 Applications

Controls discharge air temperature with instantaneous response and is ideal for industrial areas and commercial spaces such as kitchens, hotels, restaurants and boiler rooms.

Control Operation

Desired temperature at ② is set at the remote temperature selector ①. The air sensor ② senses leaving air temperature and sends an electrical signal to the amplifier ③. The amplifier then sends an electrical signal to the modulator/regulator valve ④, which adjusts gas pressure to the burner, maintaining the desired temperature at ②.

Control Sequence with Fan and Heat Switches

Fan and heat switches are included when a remote control station is ordered as an option.

Fan Switch On

Optional damper opens, damper end switch closes, fan motor starter is energized, fan runs.

The freeze-stat will stop the fan if the discharge leaving air temperature is below 45 F, three minutes after the fan is turned on.

Fan Switch Off

Optional damper closes, damper end switch opens, fan motor starter is de-energized, fan is off.

Heat Switch On

If the fan switch is on, and the air flow switch closes, power is applied to the flame failure safeguard relay to begin predetermined ignition sequence.

Note: The fan switch must be on, or the burner will not light, even if the heat switch is on.

Heat Switch Off

Heat is off.

Controls

System 44 — Space Temperature Control

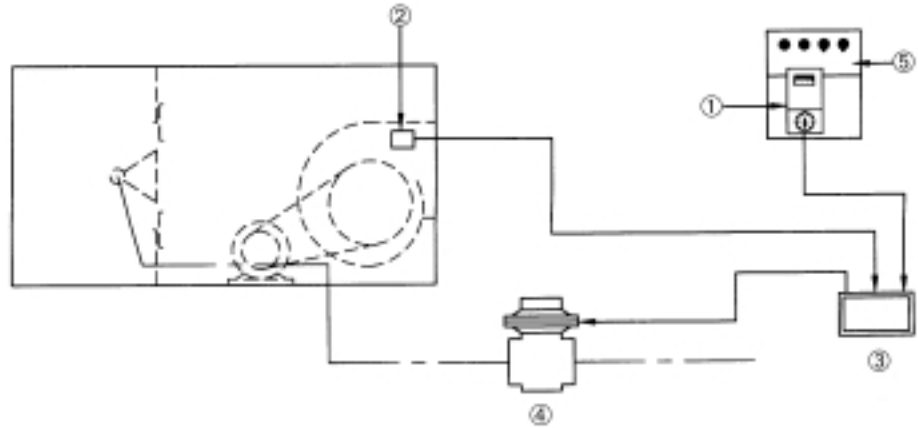

①



②



③



④



⑤

Optional

Component Description

1
Selectrastat™
Mounted on remote control station in heated area where temperature is sensed. Temperature range 55 F to 90 F.

2
Air Monitor
Installed in blower discharge. Senses temperature.

3
Amplifier
Installed in electrical control panel. Contains adjustments for maximum and minimum discharge air temperature, three calibrating potentiometers and a sensitivity adjustment.

4
Modulator/Regulator Valve
Mounts in gas piping manifold. Receives electrical signal from amplifier and adjusts gas pressure to maintain desired temperature.

5
Remote Control Station
Optional

System 44 Applications
Provides space temperature control electronically and is ideal for commercial and industrial buildings.

Temperature Control Operation
Desired temperature at ① is set at the Selectrastat on the remote control station. The Selectrastat controls the discharge air temperature as long as this temperature remains within preset maximum and minimum limits. If the discharge air temperature approaches either of the set limits, the discharge air monitor ② will signal the amplifier ③, which will adjust the discharge air temperature to a higher or lower level via the modulator/regulator valve ④. When the space temperature approaches the assigned setting, the Selectrastat resumes control.

Control Sequence with Fan and Heat Switches
Fan and heat switches are included when the remote control station is ordered as an option.

Fan Switch On
Optional damper opens, damper end switch closes, fan motor starter is energized, fan runs.

The freeze-stat will stop the fan if the discharge leaving air temperature is below 45 F, three minutes after the fan is turned on.

Fan Switch Off
Optional damper closes, damper end switch opens, fan motor starter is de-energized, fan is off.

Heat Switch On
If the fan switch is on, and the air flow switch closes, power is applied to the flame failure safeguard relay to begin predetermined ignition sequence.

Note: The fan switch must be on, or the burner will not light, even if the heat switch is on.

Heat Switch Off
Heat is off.



Electric Power

Table EP-1 — Motor Electrical Data — Single-Speed Motor

HP	ODP — 1800 RPM						Energy-Effic. ODP 1800 RPM			TEFC 1800 RPM			Energy-Effic. TEFC 1800 RPM		
	Single Phase			3-Phase			3-Phase			3-Phase			3-Phase		
HP	115	208	230	208	230	460	208	230	460	208	230	460	208	230	460
¾	11.0	5.4	5.5	2.5	2.6	1.3	NA	NA	NA	3.2	3.0	1.5	NA	NA	NA
1	12.6	6.2	6.3	3.5	2.8	1.4	3.1	2.7	1.4	3.6	2.8	1.4	3.1	2.7	1.35
1 ½	20.0	10.5	10.0	5.0	4.2	2.1	4.5	3.9	2.0	5.0	4.2	2.1	4.5	3.9	1.95
2	21.0	12.6	10.5	6.3	5.6	2.8	6.0	5.2	2.6	6.5	5.6	2.8	6.1	5.3	2.65
3	32.0	16.8	16.0	9.5	8.0	4.0	8.7	7.8	3.9	8.5	8.2	4.1	8.8	7.6	3.8
5	NA	25.0	23.0	15.4	13.2	6.6	13.8	12.0	6.0	15.0	13.4	6.7	14.2	12.4	6.2
7 ½	NA	33.0	31.0	22.0	20.0	10.0	22.5	19.6	9.8	21.5	19.2	9.6	21.4	18.6	9.3
10	NA	NA	42.0	26.4	25.2	12.6	28.0	24.4	12.2	28.0	25.2	12.6	29.0	25.0	12.5
15	NA	NA	NA	42.0	40.6	20.3	42.1	36.6	18.3	NA	38.8	19.4	41.2	36.6	18.3
20	NA	NA	NA	53.0	50.0	25.0	55.2	48.0	24.0	NA	48.0	24.0	53.8	49.0	24.5
25	NA	NA	NA	72.0	59.0	29.5	67.3	57.0	28.5	NA	60.0	30.0	63.5	57.0	28.5
30	NA	NA	NA	78.0	71.0	35.5	81.0	69.0	34.5	NA	76.0	38.0	79.8	69.0	34.5
40	NA	NA	NA	108.0	95.6	47.8	NA	92.0	46.0	NA	94.0	47.0	NA	92.0	46.0
50	NA	NA	NA	140.0	120.0	60.0	NA	116.0	58.0	NA	120.0	60.0	NA	116.0	58.0
60	NA	NA	NA	NA	145.0	72.5	NA	144.0	72.0	NA	140.0	70.0	NA	142.0	71.0

Notes:
 NA = Not Available
 FLA based on NEC ratings

Table EP-2 — Motor Electrical Data — Two-Speed Motor

HP	2-Speed/1-Winding 1800/900 RPM			2-Speed/2-Winding 1800/1200 RPM		
	3-Phase			3-Phase		
HP	208	230	460	208	230	460
¾	NA	NA	NA	NA	NA	NA
1	3.5/1.5	3.4/1.6	1.8/ .75	3.2/1.8	3.4/2.2	1.7/1.1
1 ½	5.0/2.1	4.8/2.1	2.25/.95	5.0/2.9	4.9/2.8	2.4/1.4
2	6.2/2.6	6.4/2.7	3.0/1.3	6.1/3.5	5.9/3.8	3.4/2.1
3	9.1/3.3	8.3/3.3	4.9/1.9	9.0/4.8	8.4/4.8	4.6/2.6
5	14.7/5.2	13.4/5.1	7.0/2.7	16.9/9.7	15.5/10.2	7.1/4.8
7 ½	24.0/10.0	24.5/11.0	10.5/4.2	22.0/12.3	19.5/12.3	10.0/6.0
10	29.5/11.3	30.0/12.4	13.0/5.5	30.0/17.0	28.0/17.5	13.5/7.5
15	43.0/15.2	40.0/14.0	19.4/7.2	47.0/22.0	54.0/21.0	19.0/11.0
20	56.0/20.0	54.0/21.0	26.0/10.0	56.0/29.0	51.0/27.0	24.0/12.0
25	NA	NA	31.0/10.0	NA	NA	30.0/17.0
30	NA	NA	36.6/12.4	NA	NA	38.0/18.0
40	NA	NA	50.0/16.5	NA	NA	48.0/24.0
50	NA	NA	59.0/21.0	NA	NA	59.0/30.0
60	NA	NA	NA	NA	NA	NA

Notes:
 NA = Not Available
 FLA based on NEC ratings

Dimension and Weights

Horizontal Arrangement — Single Blower 109 112 115 118

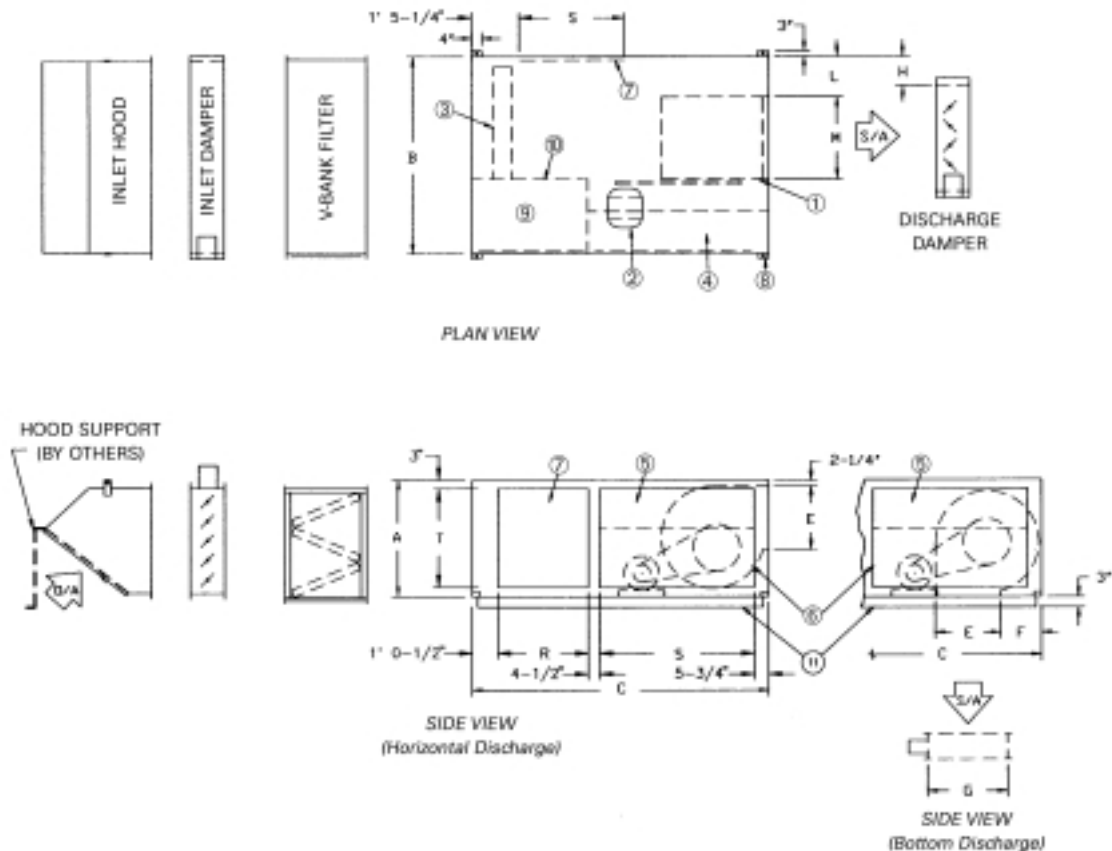

Item	Unit Components
1	Centrifugal Supply Fan
2	Fan Motor
3	Heat Source (Line Burner)
4	Control Cabinet
5	Hinged Control Cabinet Access Door
6	Motor and Drive Access Plate
7	Access Door
8	Removable Suspension Lifting Lug
9	Manifold Compartment
10	Observation Port
11	Unit Base

Inlet Hood Support (By Others)

- The purpose of hood support is to support the weight of the unit accessories which are attached to the inlet of the basic unit.
- The hood support can be made from two, 2" x 2" x 1/4" angle iron.
- One angle iron support should be located in, or close to, the outer corners of the hood. The supports can be bolted to the hood.

- The bottom of the angle iron support should be fitted with a base. The base can sit on the roof and does not have to be fixed to the roof. An isolation pad may be put between the base and the roof.

Table DW-1

Model	A	B	C	E	F	G	H	L	M	R	S	T
109	3' 0"	4' 4"	6' 5"	10 ^{-3/8"}	1' 3 ^{-1/8"}	1' 2 ^{-7/16"}	11 ^{-11/16"}	1' 2 ^{-1/2"}	11 ^{-15/16"}	1' 9"	2' 9"	2' 5"
(914)	(1321)	(1956)	(264)	(384)	(367)	(297)	(368)	(303)	(533)	(838)	(737)	
112	3' 0"	4' 4"	6' 5"	1' 1 ^{-9/16"}	1' 1 ^{-9/16"}	1' 2 ^{-7/16"}	11 ^{-11/16"}	1' 0 ^{-5/8"}	1' 3 ^{-15/16"}	1' 9"	2' 9"	2' 5"
(914)	(1321)	(1956)	(344)	(344)	(367)	(297)	(321)	(405)	(533)	(838)	(737)	
115	3' 0"	4' 4"	6' 5"	1' 4"	1' 0 ^{-3/8"}	1' 7 ^{-7/8"}	6 ^{-15/16"}	11 ^{-1/8"}	1' 6 ^{-15/16"}	1' 9"	2' 9"	2' 5"
(914)	(1321)	(1956)	(406)	(314)	(505)	(176)	(283)	(481)	(533)	(838)	(737)	
118	3' 0"	4' 4"	6' 5"	1' 7"	1' 0 ^{-3/8"}	1' 7 ^{-7/8"}	6 ^{-15/16"}	7 ^{-7/8"}	1' 10 ^{-1/16"}	1' 9"	2' 9"	2' 5"
(914)	(1321)	(1956)	(483)	(314)	(505)	(176)	(200)	(560)	(533)	(838)	(737)	

Notes:

- To permit blower shaft replacement, the side opposite the controls should have clearance equal to the unit width.
- Minimum of 3" for serviceability clearance.

Dimension and Weights

Horizontal Arrangement — Double Blower 215 218 220 222 225 230

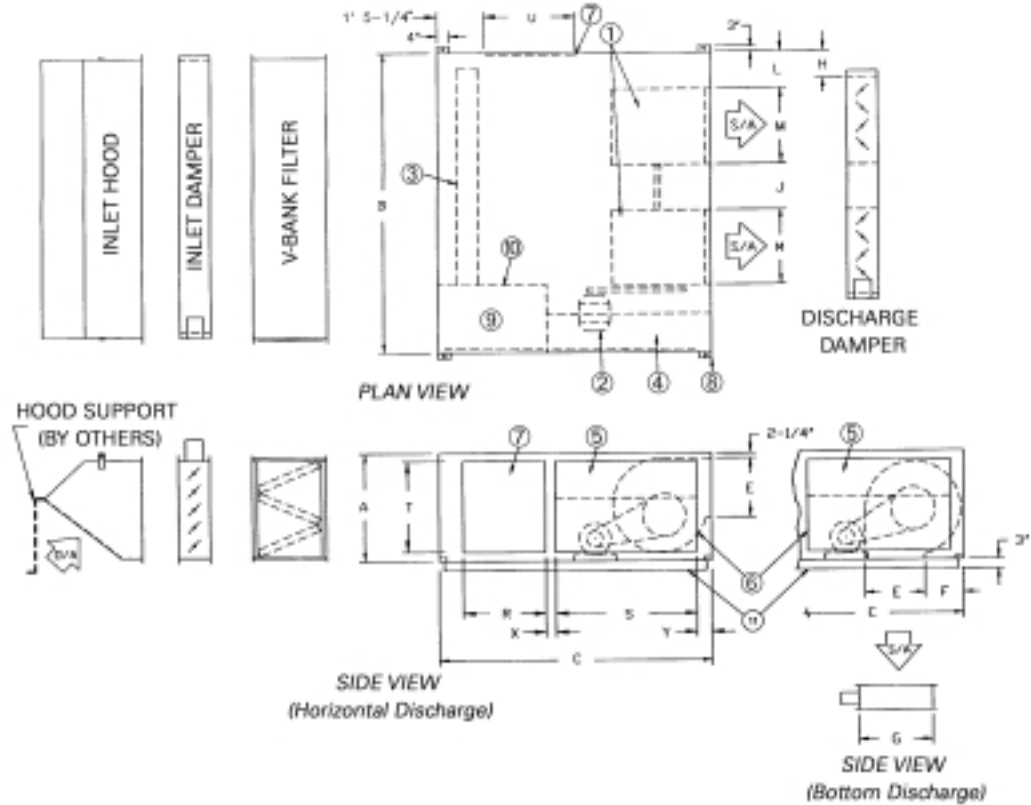

Item	Unit Components
1	Centrifugal Supply Fan
2	Fan Motor
3	Heat Source (Line Burner)
4	Control Cabinet
5	Hinged Control Cabinet Access Door
6	Motor and Drive Access Plate
7	Access Door
8	Removable Suspension Lifting Lug
9	Manifold Compartment
10	Observation Port
11	Unit Base

Inlet Hood Support (By Others)

- The purpose of hood support is to support the weight of the unit accessories which are attached to the inlet of the basic unit.
- The hood support can be made from two, 2" x 2" x 1/4" angle iron.
- One angle iron support should be located in, or close to, the outer corners of the hood. The supports can be bolted to the hood.

- The bottom of the angle iron support should be fitted with a base. The base can sit on the roof and does not have to be fixed to the roof. An isolation pad may be put between the base and the roof.

Table DW-2

Model	A	B	C	E	F	G	H	J	L	M	R	S	T	U	X	Y
215 (914)	3' 0"	7' 10"	6' 5"	1' 4"	1' 0-3/8"	1' 7-7/8"	7-1/8"	1' 10-1/2"	7-7/8"	1' 6-15/16"	1' 9"	2' 9"	2' 9"	1' 9"	4-1/2"	5-3/4"
	(2388)	(1956)	(406)	(314)	(505)	(181)	(572)	(200)	(481)	(533)	(838)	(838)	(533)	(114)	(146)	
218 (914)	3' 0"	7' 10"	6' 5"	1' 7"	1' 0-3/8"	1' 7-7/8"	7-1/8"	1' 4"	7-7/8"	1' 10-1/16"	1' 9"	2' 9"	2' 9"	1' 9"	4-1/2"	5-3/4"
	(2388)	(1956)	(483)	(314)	(505)	(181)	(406)	(200)	(560)	(533)	(838)	(838)	(533)	(114)	(146)	
220 (1219)	4' 0"	10' 10"	8' 0"	2' 0-7/8"	1' 1-3/16"	2' 4-1/4"	11-1/2"	2' 5-1/2"	1' 0-3/8"	2' 1-17/16"	2' 7"	3' 2"	3' 3"	2' 7"	0' 8"	7-1/8"
	(3302)	(2438)	(632)	(335)	(718)	(292)	(749)	(314)	(637)	(787)	(965)	(991)	(787)	(203)	(181)	
222 (1219)	4' 0"	10' 10"	8' 0"	2' 3-3/8"	1' 1-3/16"	2' 4-1/4"	11-1/2"	2' 0-5/8"	1' 0-3/8"	2' 3-9/16"	2' 7"	3' 2"	3' 3"	2' 7"	0' 8"	7-1/8"
	(3302)	(2438)	(695)	(335)	(718)	(292)	(625)	(314)	(700)	(787)	(965)	(991)	(787)	(203)	(181)	
225 (1524)	5' 0"	12' 10"	8' 0"	2' 7-3/8"	1' 5-9/16"	3' 1-3/4"	1' 2-1/2"	3' 1-5/8"	1' 3-3/8"	2' 7-1/2"	2' 1-3/4"	2' 9"	4' 3"	1' 8"	1' 2"	6-1/4"
	(3912)	(2438)	(797)	(446)	(959)	(368)	(956)	(391)	(800)	(654)	(838)	(1295)	(508)	(356)	(159)	
230 (1524)	5' 0"	12' 10"	8' 0"	3' 0-7/8"	1' 5-9/16"	3' 1-3/4"	1' 2-1/2"	2' 2-5/8"	1' 3-3/8"	3' 1"	2' 1-3/4"	2' 9"	4' 3"	1' 8"	1' 2"	6-1/4"
	(3912)	(2438)	(937)	(446)	(959)	(368)	(676)	(391)	(940)	(654)	(838)	(1295)	(508)	(356)	(159)	

Notes:

1. To permit blower shaft replacement, the side opposite the controls should have clearance equal to the unit width.
2. Minimum of 5' for serviceability clearance.
3. Supply duct connection (by others) to be "pants-legged" from unit discharge.

Dimension and Weights

Horizontal Arrangement — Single Blower
Return Air Opening Downstream of Burner
Motorized Return Air Damper — Motorized 75/25 Damper
109 112 115 118

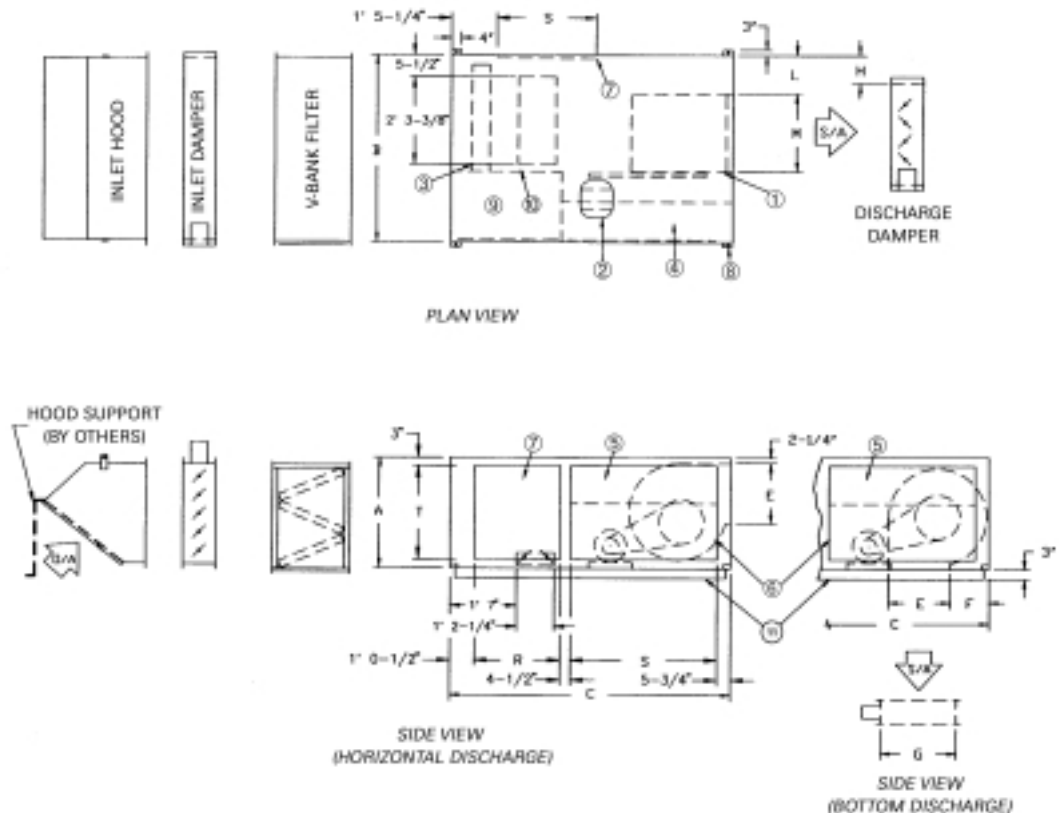

Item	Unit Components
1	Centrifugal Supply Fan
2	Fan Motor
3	Heat Source (Line Burner)
4	Control Cabinet
5	Hinged Control Cabinet Access Door
6	Motor and Drive Access Plate
7	Access Door
8	Removable Suspension Lifting Lug
9	Manifold Compartment
10	Observation Port
11	Unit Base

Inlet Hood Support (By Others)

- The purpose of hood support is to support the weight of the unit accessories which are attached to the inlet of the basic unit.
- The hood support can be made from two, 2" x 2" x 1/4" angle iron.
- One angle iron support should be located in, or close to, the outer corners of the hood. The supports can be bolted to the hood.
- The bottom of the angle iron support should be fitted with a base. The base can sit on the roof and does not have to be fixed to the roof. An isolation pad may be put between the base and the roof.

Table DW-3

Model	A	B	C	E	F	G	H	L	M	R	S	T
109	3' 0"	4' 4"	6' 5"	10 ^{-3/8"}	1' 3 ^{-1/8"}	1' 2 ^{-7/16"}	11 ^{-11/16"}	1' 2 ^{-1/2"}	11 ^{-15/16"}	1' 9"	2' 9"	2' 5"
(914)	(1321)	(1956)	(264)	(384)	(367)	(297)	(368)	(303)	(533)	(838)	(737)	
112	3' 0"	4' 4"	6' 5"	1' 1 ^{-9/16"}	1' 1 ^{-9/16"}	1' 2 ^{-7/16"}	11 ^{-11/16"}	1' 0 ^{-5/8"}	1' 3 ^{-15/16"}	1' 9"	2' 9"	2' 5"
(914)	(1321)	(1956)	(344)	(344)	(367)	(297)	(321)	(405)	(533)	(838)	(737)	
115	3' 0"	4' 4"	6' 5"	1' 4"	1' 0 ^{-3/8"}	1' 7 ^{-7/8"}	6 ^{-15/16"}	11 ^{-1/8"}	1' 6 ^{-15/16"}	1' 9"	2' 9"	2' 5"
(914)	(1321)	(1956)	(406)	(314)	(505)	(176)	(283)	(481)	(533)	(838)	(737)	
118	3' 0"	4' 4"	6' 5"	1' 7"	1' 0 ^{-3/8"}	1' 7 ^{-7/8"}	6 ^{-15/16"}	7 ^{-7/8"}	1' 10 ^{-1/16"}	1' 9"	2' 9"	2' 5"
(914)	(1321)	(1956)	(483)	(314)	(505)	(176)	(200)	(560)	(533)	(838)	(737)	

Notes:

1. To permit blower shaft replacement, the side opposite the controls should have clearance equal to the unit width.
2. Minimum of 3' for serviceability clearance.

Dimension and Weights

Horizontal Arrangement — Double Blower
Return Air Opening Downstream of Burner
Motorized Return Air Damper — Motorized 75/25 Damper
215 218 220 222 225 230

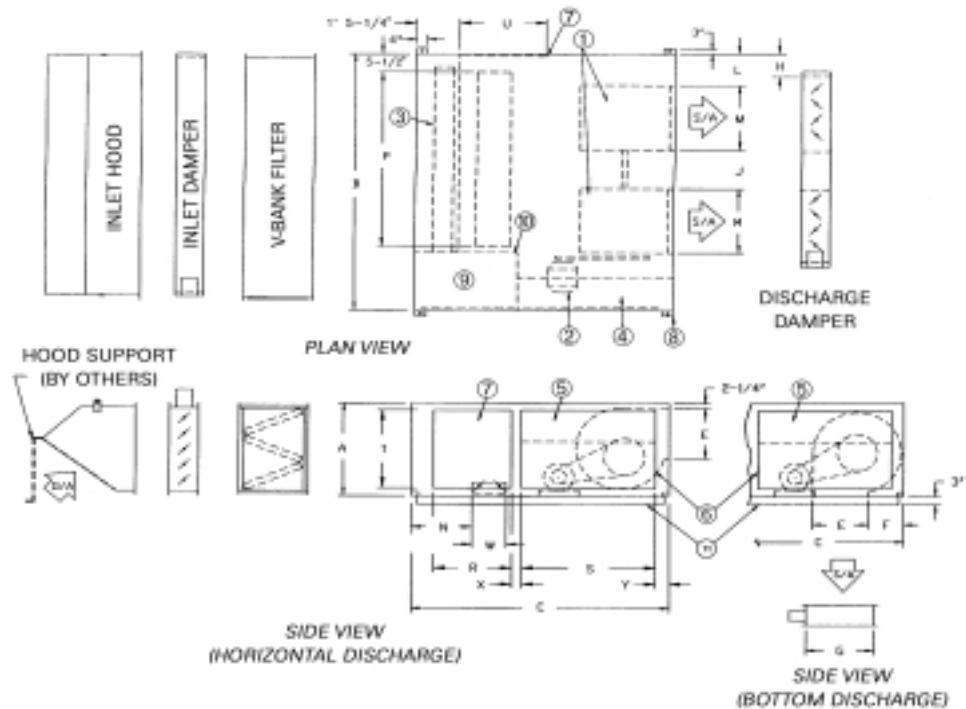

Item	Unit Components
1	Centrifugal Supply Fan
2	Fan Motor
3	Heat Source (Line Burner)
4	Control Cabinet
5	Hinged Control Cabinet Access Door
6	Motor and Drive Access Plate
7	Access Door
8	Removable Suspension Lifting Lug
9	Manifold Compartment
10	Observation Port
11	Unit Base

Inlet Hood Support (By Others)

- The purpose of hood support is to support the weight of the unit accessories which are attached to the inlet of the basic unit.
- The hood support can be made from two, 2" x 2" x 1/4" angle iron.
- One angle iron support should be located in, or close to, the outer corners of the hood. The supports can be bolted to the hood.
- The bottom of the angle iron support should be fitted with a base. The base can sit on the roof and does not have to be fixed to the roof. An isolation pad may be put between the base and the roof.

Table DW-4

Model	A	B	C	F	F	G	H	J	L	M	N	P	R	S	T	U	W	X	Y
215	3' 0"	7' 10"	6' 5"	1' 4"	1' 0-3/8"	1' 7-7/8"	7-1/8"	1' 10-1/2"	7-7/8"	1' 6-15/16"	1' 7"	5' 5-3/4"	1' 9"	2' 9"	2' 5"	1' 9"	1' 2-1/4"	4-1/2"	5-3/4"
(914)	(2388)	(1956)	(406)	(314)	(505)	(181)	(572)	(200)	(481)	(483)	(1670)	(533)	(838)	(737)	(533)	(362)	(114)	(146)	
218	3' 0"	7' 10"	6' 5"	1' 7"	1' 0-3/8"	1' 7-7/8"	7-1/8"	1' 4"	7-7/8"	1' 10-1/16"	1' 7"	5' 5-3/4"	1' 9"	2' 9"	2' 5"	1' 9"	1' 2-1/4"	4-1/2"	5-3/4"
(914)	(2388)	(1956)	(483)	(314)	(505)	(181)	(406)	(200)	(560)	(483)	(1670)	(533)	(838)	(737)	(533)	(362)	(114)	(146)	
220	4' 0"	10' 10"	8' 0"	2' 0-7/8"	1' 1-3/16"	2' 4-1/4"	11-1/2"	2' 5-1/2"	1' 0-3/8"	2' 1-1/16"	1' 7"	7' 3-3/8"	2' 9"	3' 2"	3' 3"	2' 7"	1' 2-1/4"	0' 8"	7-1/8"
(1219)	(3302)	(2438)	(632)	(335)	(718)	(292)	(749)	(314)	(637)	(483)	(2219)	(838)	(965)	(991)	(787)	(362)	(203)	(181)	
222	4' 0"	10' 10"	8' 0"	2' 3-3/8"	1' 1-3/16"	2' 4-1/4"	11-1/2"	2' 0-5/8"	1' 0-3/8"	2' 3-9/16"	1' 7"	7' 3-3/8"	2' 9"	3' 2"	3' 3"	2' 7"	1' 2-1/4"	0' 8"	7-1/8"
(1219)	(3302)	(2438)	(695)	(335)	(718)	(292)	(625)	(314)	(700)	(483)	(2219)	(838)	(965)	(991)	(787)	(362)	(203)	(181)	
225	5' 0"	12' 10"	8' 0"	2' 7-3/8"	1' 5-9/16"	3' 1-3/4"	1' 2-1/2"	3' 1-5/8"	1' 3-3/8"	2' 7-1/2"	11-13/16"	9' 3-3/8"	2' 1-3/4"	3' 2"	4' 3"	1' 8"	1' 8-1/4"	1' 2"	6-1/4"
(1524)	(3912)	(2438)	(797)	(446)	(959)	(368)	(956)	(391)	(800)	(300)	(2829)	(654)	(965)	(1295)	(508)	(514)	(356)	(159)	
230	5' 0"	12' 10"	8' 0"	3' 0-7/8"	1' 5-9/16"	3' 1-3/4"	1' 2-1/2"	2' 2-5/8"	1' 3-3/8"	3' 1"	11-13/16"	9' 3-3/8"	2' 1-3/4"	2' 9"	4' 3"	1' 8"	1' 8-1/4"	1' 2"	6-1/4"
(1524)	(3912)	(2438)	(937)	(446)	(959)	(368)	(676)	(391)	(940)	(300)	(2829)	(654)	(838)	(1295)	(508)	(514)	(356)	(159)	

Notes:
 1. To permit blower shaft replacement, the side opposite the controls should have clearance equal to the unit width.
 2. Minimum of 5' for serviceability clearance.
 3. Supply duct connection (by others) to be "pants-legged" from unit discharge.

Dimension and Weights

Horizontal Arrangement — Single Blower With Mixing Box 109 112 115 118

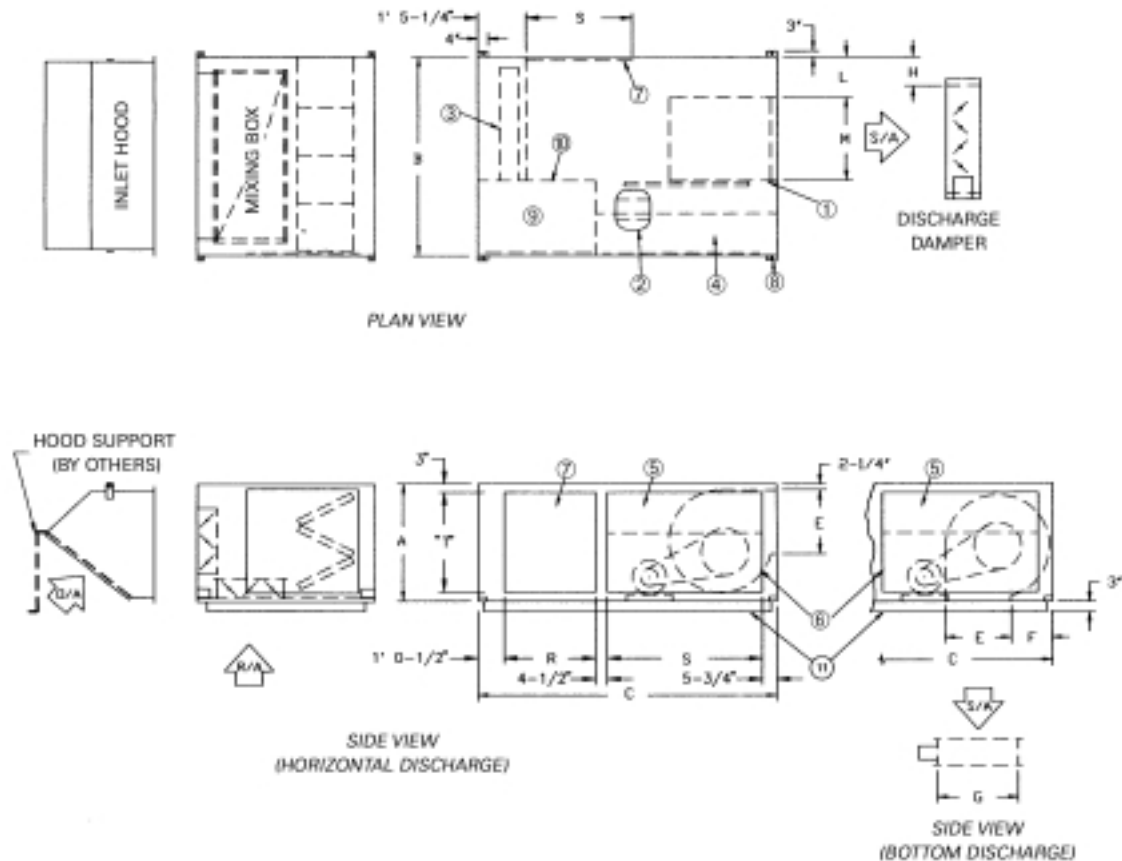

Item	Unit Components
1	Centrifugal Supply Fan
2	Fan Motor
3	Heat Source (Line Burner)
4	Control Cabinet
5	Hinged Control Cabinet Access Door
6	Motor and Drive Access Plate
7	Access Door
8	Removable Suspension Lifting Lug
9	Manifold Compartment
10	Observation Port
11	Unit Base

Inlet Hood Support (By Others)

- The purpose of hood support is to support the weight of the unit accessories which are attached to the inlet of the basic unit.
- The hood support can be made from two, 2" x 2" x 1/4" angle iron.
- One angle iron support should be located in, or close to, the outer corners of the hood. The supports can be bolted to the hood.

- The bottom of the angle iron support should be fitted with a base. The base can sit on the roof and does not have to be fixed to the roof. An isolation pad may be put between the base and the roof.

Table DW-5

Model	A	B	C	E	F	G	H	L	M	R	S	T
109	3' 0"	4' 4"	6' 5"	10 ^{3/8} "	1' 3 ^{-1/8} "	1' 2 ^{-7/16} "	11 ^{-11/16} "	1' 2 ^{-1/2} "	11 ^{-15/16} "	1' 9"	2' 9"	2' 5"
(914)	(1321)	(1956)	(264)	(384)	(367)	(297)	(368)	(303)	(533)	(838)	(737)	
112	3' 0"	4' 4"	6' 5"	1' 1 ^{-9/16} "	1' 1 ^{-9/16} "	1' 2 ^{-7/16} "	11 ^{-11/16} "	1' 0 ^{-5/8} "	1' 3 ^{-15/16} "	1' 9"	2' 9"	2' 5"
(914)	(1321)	(1956)	(344)	(344)	(367)	(297)	(321)	(405)	(533)	(838)	(737)	
115	3' 0"	4' 4"	6' 5"	1' 4"	1' 0 ^{-3/8} "	1' 7 ^{-7/8} "	6 ^{-15/16} "	11 ^{-1/8} "	1' 6 ^{-15/16} "	1' 9"	2' 9"	2' 5"
(914)	(1321)	(1956)	(406)	(314)	(505)	(176)	(283)	(481)	(533)	(838)	(737)	
118	3' 0"	4' 4"	6' 5"	1' 7"	1' 0 ^{-3/8} "	1' 7 ^{-7/8} "	6 ^{-15/16} "	7 ^{-7/8} "	1' 10 ^{-1/16} "	1' 9"	2' 9"	2' 5"
(914)	(1321)	(1956)	(483)	(314)	(505)	(176)	(200)	(560)	(533)	(838)	(737)	

Notes:

1. To permit blower shaft replacement, the side opposite the controls should have clearance equal to the unit width.
2. Minimum of 3" for serviceability clearance.

Dimension and Weights

Horizontal Arrangement — Double Blower With Mixing Box 215 218 220 222 225 230

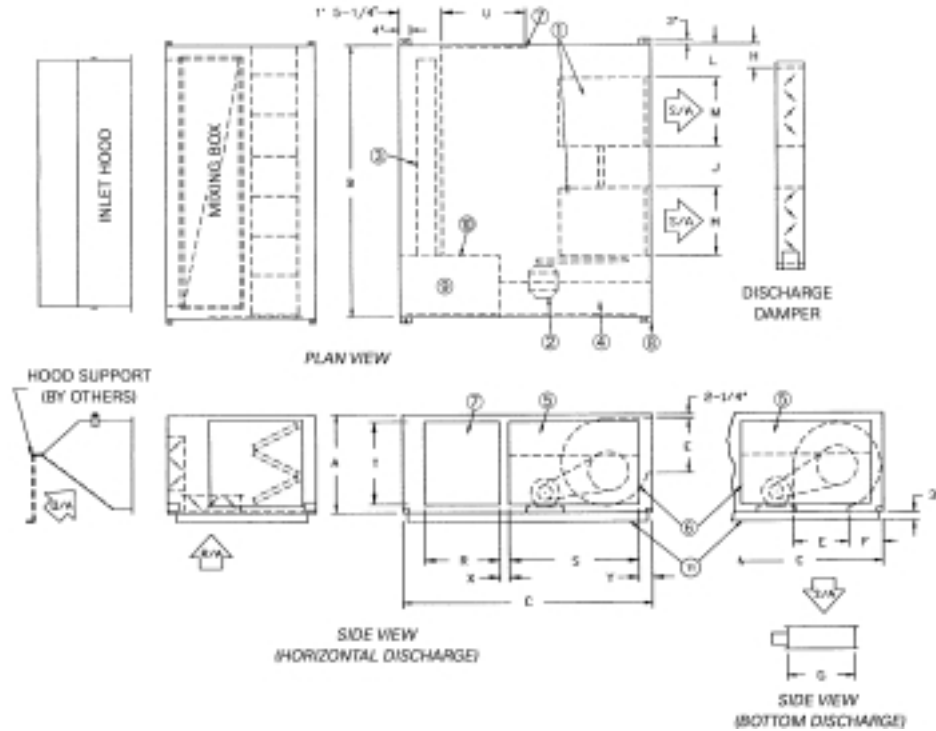

Item	Unit Components
1	Centrifugal Supply Fan
2	Fan Motor
3	Heat Source (Line Burner)
4	Control Cabinet
5	Hinged Control Cabinet Access Door
6	Motor and Drive Access Plate
7	Access Door
8	Removable Suspension Lifting Lug
9	Manifold Compartment
10	Observation Port
11	Unit Base

Inlet Hood Support (By Others)

- The purpose of hood support is to support the weight of the unit accessories which are attached to the inlet of the basic unit.
- The hood support can be made from two, 2" x 2" x 1/4" angle iron.
- One angle iron support should be located in, or close to, the outer corners of the hood. The supports can be bolted to the hood.

- The bottom of the angle iron support should be fitted with a base. The base can sit on the roof and does not have to be fixed to the roof. An isolation pad may be put between the base and the roof.

Table DW-6

Model	A	B	C	E	F	G	H	J	L	M	R	S	T	U	X	Y
215	3' 0"	7' 10"	6' 5"	1' 4"	1' 0-3/8"	1' 7-7/8"	7-7/8"	1' 10-1/2"	7-7/8"	1' 6-15/16"	1' 9"	2' 9"	2' 9"	1' 9"	4-1/2"	5-3/4"
	(914)	(2388)	(1956)	(406)	(314)	(505)	(181)	(572)	(200)	(481)	(533)	(838)	(838)	(533)	(114)	(146)
218	3' 0"	7' 10"	6' 5"	1' 7"	1' 0-3/8"	1' 7-7/8"	7-7/8"	1' 4"	7-7/8"	1' 10-1/16"	1' 9"	2' 9"	2' 9"	1' 9"	4-1/2"	5-3/4"
	(914)	(2388)	(1956)	(483)	(314)	(505)	(181)	(406)	(200)	(560)	(533)	(838)	(838)	(533)	(114)	(146)
220	4' 0"	10' 10"	8' 0"	2' 0-7/8"	1' 1-3/16"	2' 4-1/4"	11-1/2"	2' 5-1/2"	1' 0-3/8"	2' 1-1/16"	2' 7"	3' 2"	3' 3"	2' 7"	0' 8"	7-1/8"
	(1219)	(3302)	(2438)	(632)	(335)	(718)	(292)	(749)	(314)	(637)	(787)	(965)	(991)	(787)	(203)	(181)
222	4' 0"	10' 10"	8' 0"	2' 3-3/8"	1' 1-3/16"	2' 4-1/4"	11-1/2"	2' 0-5/8"	1' 0-3/8"	2' 3-9/16"	2' 7"	3' 2"	3' 3"	2' 7"	0' 8"	7-1/8"
	(1219)	(3302)	(2438)	(695)	(335)	(718)	(292)	(625)	(314)	(700)	(787)	(965)	(991)	(787)	(203)	(181)
225	5' 0"	12' 10"	8' 0"	2' 7-3/8"	1' 5-9/16"	3' 1-3/4"	1' 2-1/2"	3' 1-5/8"	1' 3-3/8"	2' 7-1/2"	2' 1-3/4"	2' 9"	4' 3"	1' 8"	1' 2"	6-1/4"
	(1524)	(3912)	(2438)	(797)	(446)	(959)	(368)	(956)	(391)	(800)	(654)	(838)	(1295)	(508)	(356)	(159)
230	5' 0"	12' 10"	8' 0"	3' 0-7/8"	1' 5-9/16"	3' 1-3/4"	1' 2-1/2"	2' 2-5/8"	1' 3-3/8"	3' 1"	2' 1-3/4"	2' 9"	4' 3"	1' 8"	1' 2"	6-1/4"
	(1524)	(3912)	(2438)	(937)	(446)	(959)	(368)	(676)	(391)	(940)	(654)	(838)	(1295)	(508)	(356)	(159)

Notes:

1. To permit blower shaft replacement, the side opposite the controls should have clearance equal to the unit width.
2. Minimum of 5' for serviceability clearance.
3. Supply duct connection (by others) to be "pants-legged" from unit discharge.

Dimension and Weights

Vertical Arrangement — Single Blower 100% Outside Air—Arrangement 4

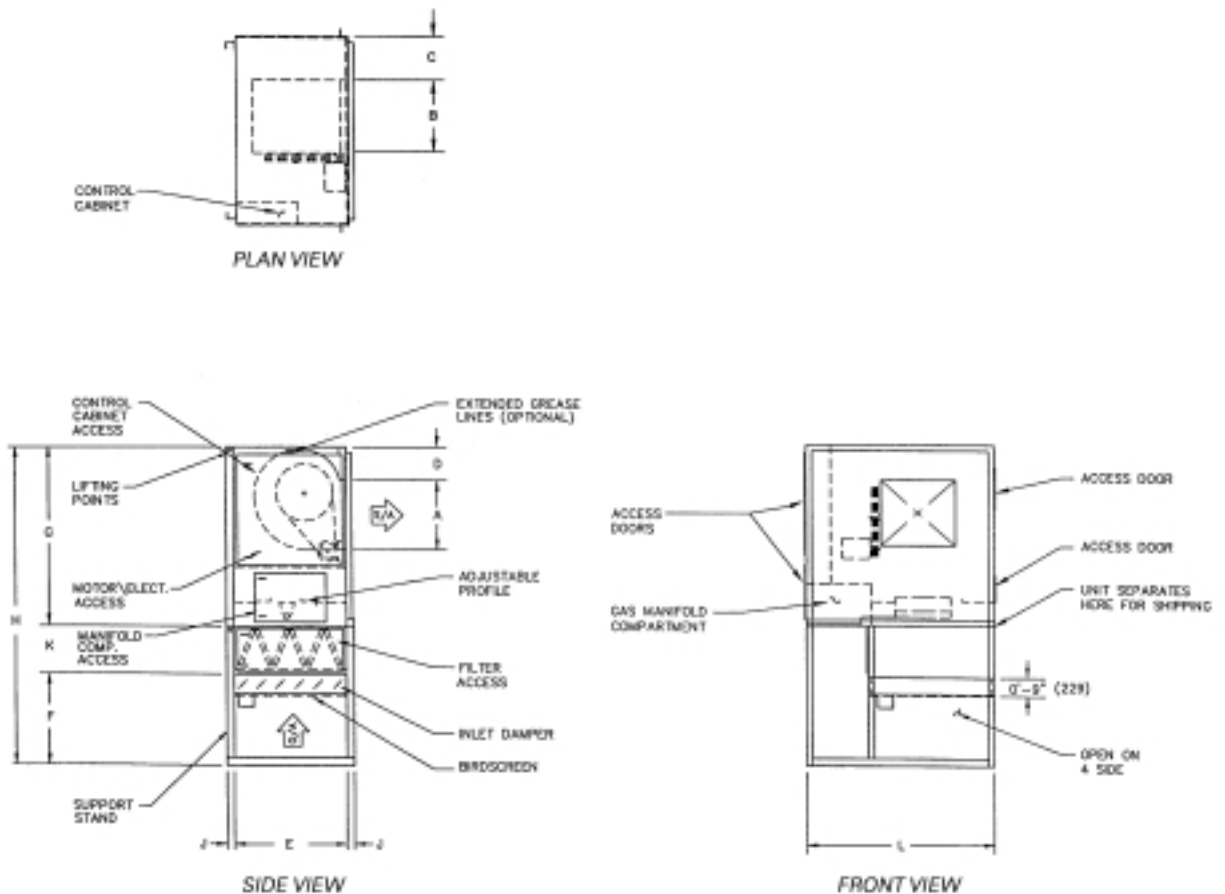

Table DW-7

Model	A	B	C	D	E	F	G	H	J	K	L
109	10 ^{3/8} (264)	11 ^{-15/16} (303)	1' 2-1/2" (368)	1' 3 ^{-1/8} (384)	3' 0" (914)	3' 0" (914)	6' 5" (1956)	11' 3" (3429)	0' 3" (76)	1' 10" (559)	4' 4" (1321)
112	1' 1 ^{-9/16} (344)	1' 3 ^{-15/16} (405)	1' 1/2" (318)	1' 1 ^{-9/16} (344)	3' 0" (914)	3' 0" (914)	6' 5" (1956)	11' 3" (3429)	0' 3" (76)	1' 10" (559)	4' 4" (1321)
115	1' 4" (406)	1' 6 ^{-15/16} (481)	11 ^{-1/8} (283)	1' 3 ^{8/8} (314)	3' 0" (914)	3' 0" (914)	6' 5" (1956)	11' 3" (3429)	0' 3" (76)	1' 10" (559)	4' 4" (1321)
118	1' 7" (483)	1' 10 ^{-1/16} (560)	7 ^{-7/8} (200)	1' 3 ^{8/8} (314)	3' 0" (914)	3' 0" (914)	6' 5" (1956)	11' 3" (3429)	0' 3" (76)	1' 10" (559)	4' 4" (1321)

Notes:

1. Factory furnished support stand shipped separately for field mounting by others.
2. V-bank and inlet damper shown are optional components.
3. If V-bank section is ordered, it will ship mounted to the support stand.
4. If inlet damper is ordered, it will ship mounted in the support stand.
5. Refer to page 35 for unit weights.

Dimension and Weights

Vertical Arrangement —Double Blower 100% Outside Air—Arrangement 4

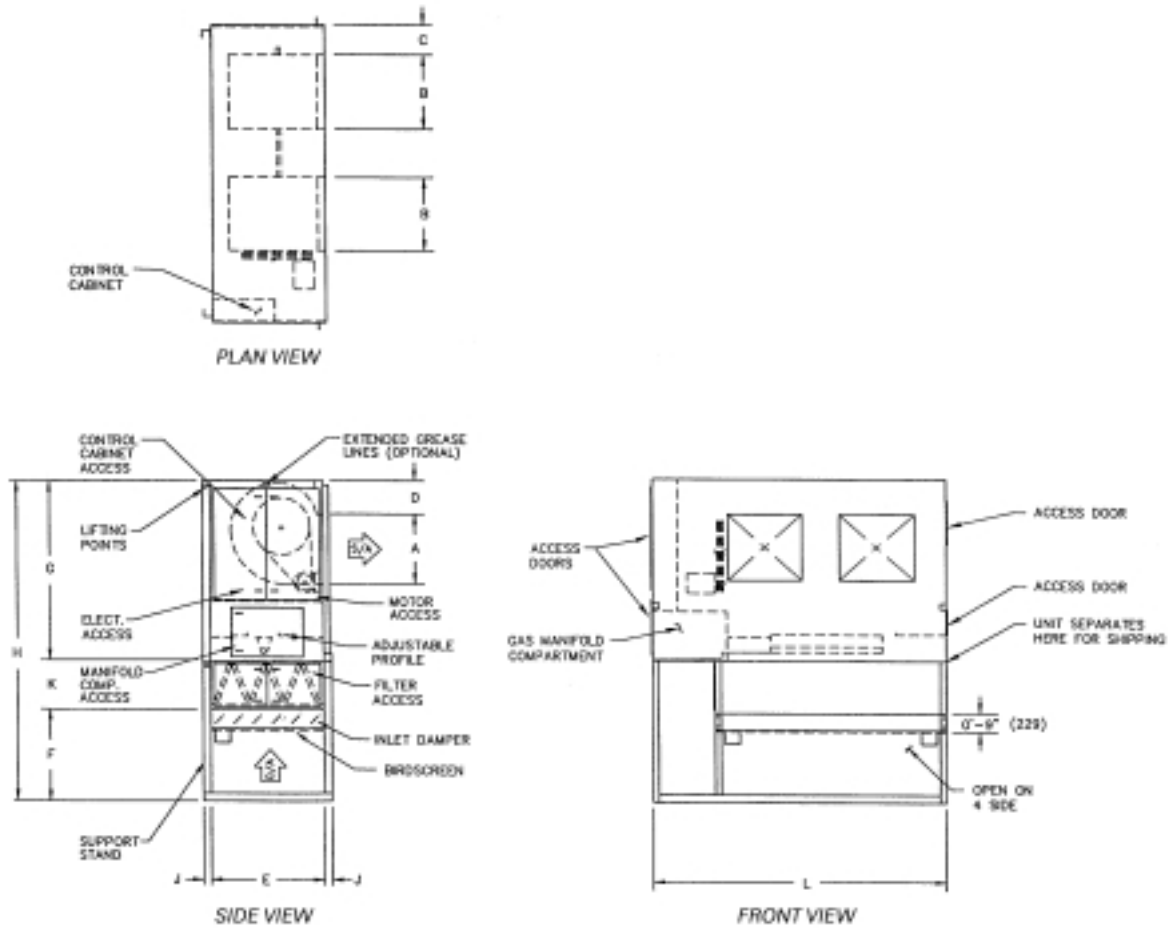

Table DW-8

Model	A	B	C	D	E	F	G	H	J	K	L	P
215	1' 4" (406)	1' 6 ^{15/16} " (481)	0' 7 ^{7/8} " (200)	1' 0 ^{3/8} " (314)	3' 0" (914)	3' 0" (914)	6' 5" (1956)	11' 3" (3429)	0' 3" (76)	1' 10" (559)	7' 10" (2388)	1' 10 ^{1/4} " (565)
218	1' 7" (483)	1' 10 ^{11/16} " (560)	0' 7 ^{7/8} " (200)	1' 0 ^{3/8} " (314)	3' 0" (914)	3' 0" (914)	6' 5" (1956)	11' 3" (3429)	0' 3" (76)	1' 10" (559)	7' 10" (2388)	1' 4" (406)
220	2' 0 ^{7/8} " (632)	2' 1 ^{1/16} " (637)	1' 0 ^{3/8} " (314)	1' 1 ^{3/16} " (335)	4' 0" (1219)	4' 0" (1219)	8' 0" (2438)	13' 10" (4216)	0' 4" (102)	1' 10" (559)	10' 10" (3302)	2' 5 ^{5/8} " (752)
222	2' 3 ^{3/8} " (695)	2' 3 ^{9/16} " (700)	1' 0 ^{3/8} " (314)	1' 1 ^{3/16} " (335)	4' 0" (1219)	4' 0" (1219)	8' 0" (2438)	13' 10" (4216)	0' 4" (102)	1' 10" (559)	10' 10" (3302)	2' 5 ^{5/8} " (752)
225	2' 7 ^{3/8} " (797)	2' 7 ^{1/2} " (800)	1' 3 ^{3/8} " (391)	1' 5 ^{9/16} " (446)	5' 0" (1524)	4' 0" (1219)	8' 0" (2438)	14' 4" (4369)	0' 4" (102)	2' 4" (711)	12' 10" (3912)	3' 1 ^{5/8} " (956)
230	3' 0 ^{7/8} " (937)	3' 1" (940)	1' 3 ^{3/8} " (391)	1' 5 ^{9/16} " (446)	5' 0" (1524)	4' 0" (1219)	8' 0" (2438)	14' 4" (4369)	0' 4" (102)	2' 4" (711)	12' 10" (3912)	2' 2 ^{5/8} " (676)

Notes:

- Supply duct connection (by others) to be "pants-legged" from unit discharge
- Factory furnished support stand shipped separately for field mounting by others.
- V-bank and inlet damper shown are optional components.
- If V-bank section is ordered, it will ship mounted to the support stand.
- If inlet damper is ordered, it will ship mounted in the support stand.
- Refer to page 35 for unit weights.

Dimension and Weights

Vertical Arrangement — Single Blower Return Air Downstream of Burner—Arrangement 4

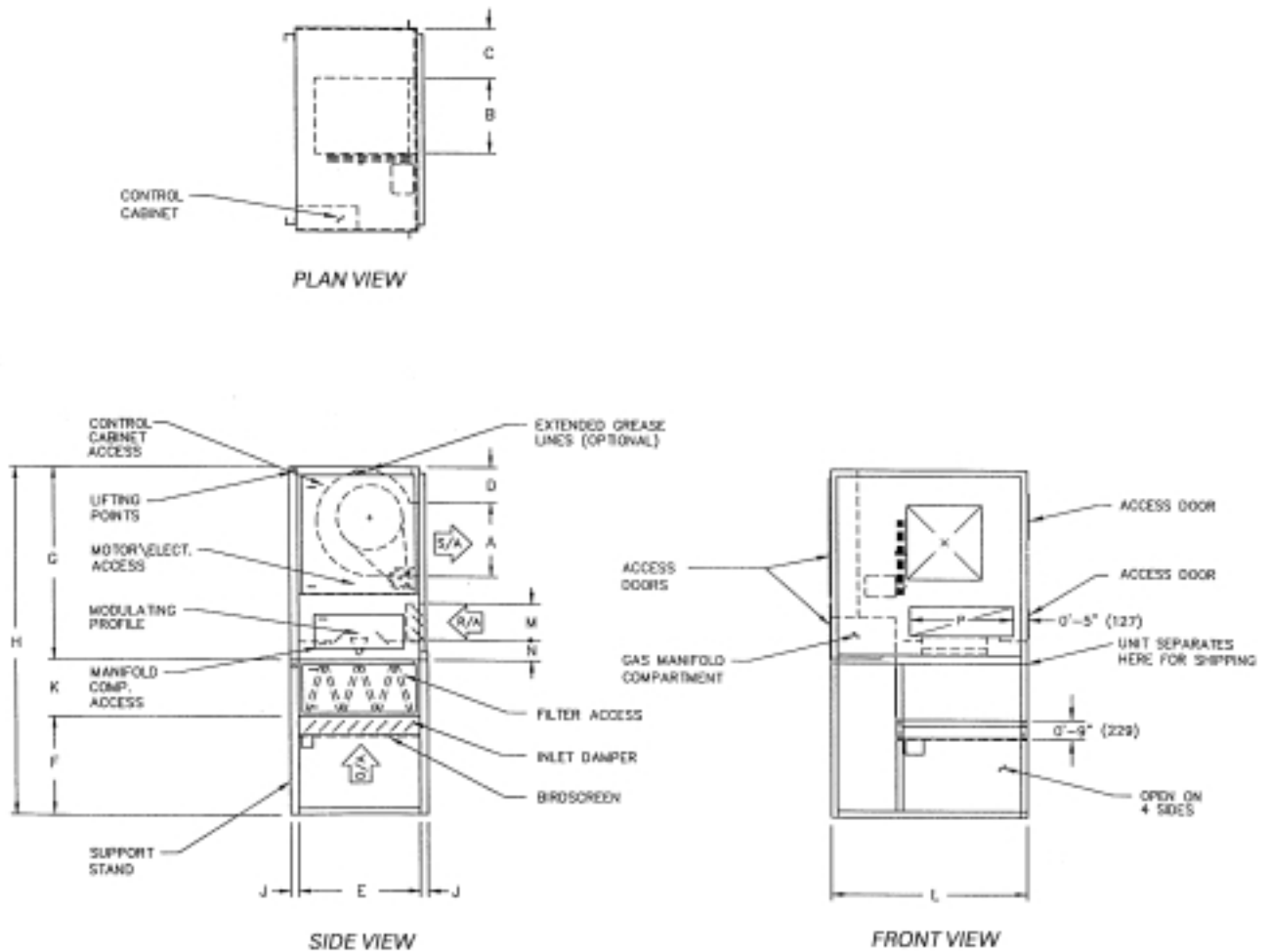

Table DW-9

Model	A	B	C	D	E	F	G	H	J	K	L	M	N	P
109	10 ⁻³⁸ (264)	11 ^{-15/16} (303)	1' 2-1/2" (368)	1' 3-1/8" (384)	3' 0" (914)	3' 0" (914)	6' 5" (1956)	11' 3" (3429)	0' 3" (76)	1' 10" (559)	4' 4" (1321)	1' 2-1/4" (362)	1' 7" (483)	2' 3-3/4" (705)
112	1' 1-3/16" (344)	1' 3-15/16" (405)	1' 1/2" (318)	1' 1-9/16" (344)	3' 0" (914)	3' 0" (914)	6' 5" (1956)	11' 3" (3429)	0' 3" (76)	1' 10" (559)	4' 4" (1321)	1' 2-1/4" (362)	1' 7" (483)	2' 3-3/4" (705)
115	1' 4" (406)	1' 6-15/16" (481)	11-1/8" (283)	1' 3/8" (314)	3' 0" (914)	3' 0" (914)	6' 5" (1956)	11' 3" (3429)	0' 3" (76)	1' 10" (559)	4' 4" (1321)	1' 2-1/4" (362)	1' 7" (483)	2' 3-3/4" (705)
118	1' 7" (483)	1' 10-1/16" (560)	7-7/8" (200)	1' 3/8" (314)	3' 0" (914)	3' 0" (914)	6' 5" (1956)	11' 3" (3429)	0' 3" (76)	1' 10" (559)	4' 4" (1321)	1' 2-1/4" (362)	1' 7" (483)	2' 3-3/4" (705)

- Notes:
1. Factory furnished support stand shipped separately for field mounting by others.
 2. V-bank and inlet damper shown are optional components.
 3. If V-bank section is ordered, it will ship mounted to the support stand.
 4. If inlet damper is ordered, it will ship mounted in the support stand.
 5. Refer to page 35 for unit weights.



Dimension and Weights

Vertical Arrangement — Double Blower Return Air Downstream of Burner—Arrangement 4

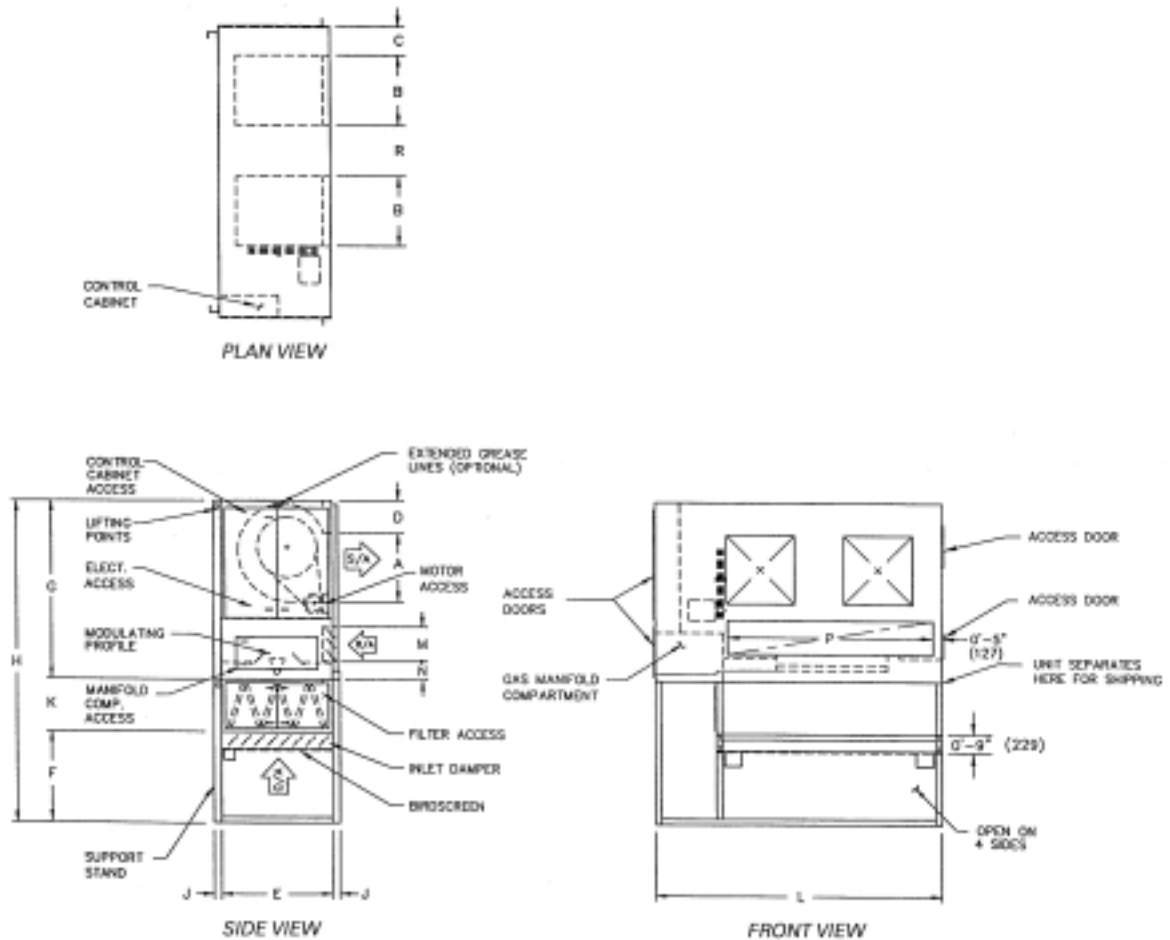

Table DW-10

Model	A	B	C	D	E	F	G	H	J	K	L	M	N	P	R
215	1' 4" (406)	1' 6-15/16" (481)	7-7/8" (200)	1' 0-3/8" (314)	3' 0" (914)	3' 0" (914)	6' 5" (1956)	11' 3" (3429)	0' 3" (76)	1' 10" (559)	7' 10" (2388)	1' 2-1/4" (362)	1' 7" (483)	5' 5-3/4" (1670)	1' 10-1/4" (565)
218	1' 7" (483)	1' 10-1/16" (560)	7-7/8" (200)	1' 3/8" (314)	3' 0" (914)	3' 0" (914)	6' 5" (1956)	11' 3" (3429)	0' 3" (76)	1' 10" (559)	7' 10" (2388)	1' 2-1/4" (362)	1' 7" (483)	5' 5-3/4" (1670)	1' 4" (406)
220	2' 0-7/8" (632)	2' 1-1/16" (637)	1' 0-3/8" (314)	1' 1-3/16" (335)	4' 0" (1219)	4' 0" (1219)	8' 0" (2438)	13' 10" (4216)	0' 4" (102)	1' 10" (559)	10' 10" (3302)	1' 2-1/4" (362)	1' 7" (483)	7' 3-3/8" (2219)	2' 5-5/8" (752)
222	2' 3-3/8" (695)	2' 3-9/16" (700)	1' 0-3/8" (314)	1' 1-3/16" (335)	4' 0" (1219)	4' 0" (1219)	8' 0" (2438)	13' 10" (4216)	0' 4" (102)	1' 10" (559)	10' 10" (3302)	1' 2-1/4" (362)	1' 7" (483)	7' 3-3/8" (2219)	2' 5-5/8" (752)
225	2' 7-3/8" (797)	2' 7-1/2" (800)	1' 3-3/8" (391)	1' 5-9/16" (446)	5' 0" (1524)	4' 0" (1219)	8' 0" (2438)	14' 4" (4369)	0' 4" (102)	2' 4" (711)	12' 10" (3912)	1' 8-1/4" (514)	1' 0-5/16" (313)	9' 3-3/8" (2829)	3' 1-5/8" (956)
230	3' 0-7/8" (937)	3' 1" (940)	1' 3-3/8" (391)	1' 5-9/16" (446)	5' 0" (1524)	4' 0" (1219)	8' 0" (2438)	14' 4" (4369)	0' 4" (102)	2' 4" (711)	12' 10" (3912)	1' 8-1/4" (514)	1' 0-5/16" (313)	9' 3-3/8" (2829)	2' 2-5/8" (676)

Notes:

1. Supply duct connection (by others) to be "pants-legged" from unit discharge.
2. Factory furnished support stand shipped separately for field mounting by others.
3. V-bank and inlet damper shown are optional components.
4. If V-bank section is ordered, it will ship mounted to the support stand.
5. If inlet damper is ordered, it will ship mounted in the support stand.
6. Refer to page 35 for unit weights.

Dimension and Weights

Vertical Arrangement Single Blower with Mixing Box—Arrangement 4

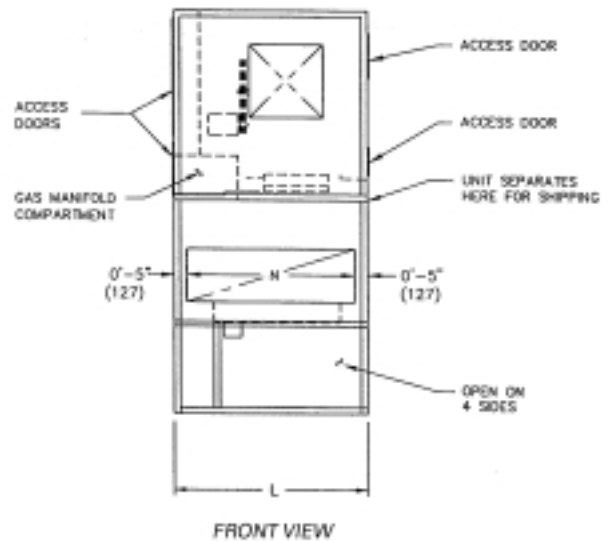
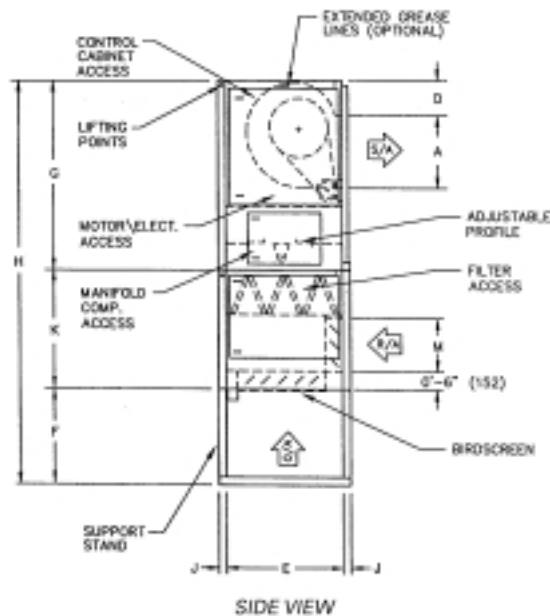
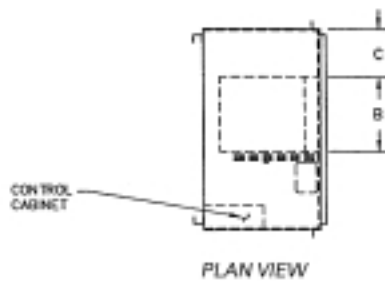

Table DW-11

Model	A	B	C	D	E	F	G	H	J	K	L	M	N
109	10 ⁻³⁸ " (264)	11 ^{-15/16} " (303)	1' 2-1/2" (368)	1' 3-1/8" (384)	3' 0" (914)	3' 0" (914)	6' 5" (1956)	13' 11" (4242)	0' 3" (76)	4' 6" (1372)	4' 4" (1321)	1' 8-1/4" (514)	3' 6" (1067)
112	1' 1 ^{-9/16} " (344)	1' 3 ^{-15/16} " (405)	1' 1/2" (318)	1' 1 ^{-9/16} " (344)	3' 0" (914)	3' 0" (914)	6' 5" (1956)	13' 11" (4242)	0' 3" (76)	4' 6" (1372)	4' 4" (1321)	1' 8-1/4" (514)	3' 6" (1067)
115	1' 4" (406)	1' 6 ^{-15/16} " (481)	11 ^{-1/8} " (283)	1' 3/8" (314)	3' 0" (914)	3' 0" (914)	6' 5" (1956)	13' 11" (4242)	0' 3" (76)	4' 6" (1372)	4' 4" (1321)	1' 8-1/4" (514)	3' 6" (1067)
118	1' 7" (483)	1' 10 ^{-1/16} " (560)	7 ^{-7/8} " (200)	1' 3/8" (314)	3' 0" (914)	3' 0" (914)	6' 5" (1956)	13' 11" (4242)	0' 3" (76)	4' 6" (1372)	4' 4" (1321)	1' 8-1/4" (514)	3' 6" (1067)

Notes:

1. Factory furnished support stand shipped separately for field mounting by others.
2. V-bank and inlet damper shown are optional components.
3. If V-bank section is ordered, it will ship mounted to the support stand.
4. If inlet damper is ordered, it will ship mounted in the support stand.
5. Refer to page 35 for unit weights.



Dimension and Weights

Vertical Arrangement Double Blower With Mixing Box—Arrangement 4

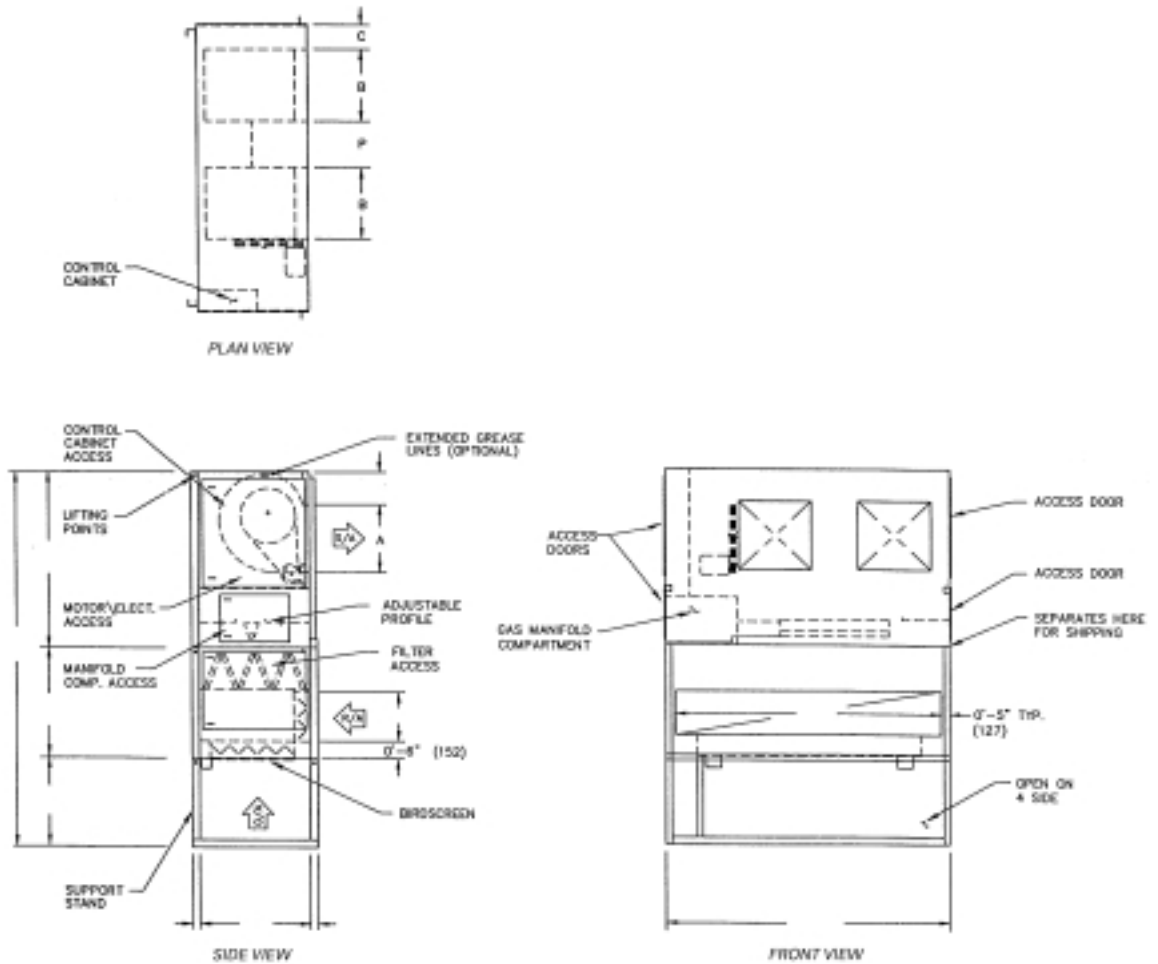

Table DW-12

Model	A	B	C	D	E	F	G	H	J	K	L	M	N	P
215	1' 4" (406)	1' 6-15/16" (481)	7-7/8" (200)	1' 3/8" (314)	3' 0" (914)	3' 0" (914)	6' 5" (1956)	13' 11" (4242)	0' 3" (76)	4' 6" (1372)	7' 10" (2388)	1' 8-1/4" (514)	7' 0" (2134)	1' 10-1/4" (565)
218	1' 7" (483)	1' 10-1/16" (560)	7-7/8" (200)	1' 3/8" (314)	3' 0" (914)	3' 0" (914)	6' 5" (1956)	13' 11" (4242)	0' 3" (76)	4' 6" (1372)	7' 10" (2388)	1' 8-1/4" (514)	7' 0" (2134)	1' 4" (406)
220	2' 0-7/8" (632)	2' 1-1/16" (637)	1' 0-3/8" (314)	1' 1-3/16" (335)	4' 0" (1219)	4' 0" (1219)	8' 0" (2438)	17' 0" (5182)	0' 4" (102)	5' 0" (1524)	10' 10" (3302)	1' 8-1/4" (514)	10' 0" (3048)	2' 5-1/2" (749)
222	2' 3-3/8" (695)	2' 3-9/16" (700)	1' 0-3/8" (314)	1' 1-3/16" (335)	4' 0" (1219)	4' 0" (1219)	8' 0" (2438)	17' 0" (5182)	0' 4" (102)	5' 0" (1524)	10' 10" (3302)	1' 8-1/4" (514)	10' 0" (3048)	2' 0-5/8" (625)
225	2' 7-3/8" (797)	2' 7-1/2" (800)	1' 3-3/8" (391)	1' 5-9/16" (446)	5' 0" (1524)	4' 0" (1219)	8' 0" (2438)	17' 5" (5309)	0' 4" (102)	5' 5" (1651)	12' 10" (3912)	2' 2-1/4" (667)	12' 0" (3658)	3' 1-5/8" (957)
230	3' 0-7/8" (937)	3' 1" (940)	1' 3-3/8" (391)	1' 5-9/16" (446)	5' 0" (1524)	4' 0" (1219)	8' 0" (2438)	17' 5" (5309)	0' 4" (102)	5' 5" (1651)	12' 10" (3912)	2' 2-1/4" (667)	12' 0" (3658)	2' 2-5/8" (676)

Notes:

1. Supply duct connection (by others) to be "pants-legged" from unit discharge
2. Factory furnished support stand shipped separately for field mounting by others.
3. V-bank and Inlet damper shown are optional components.
4. If V-bank section is ordered, it will ship mounted to the support stand.
5. If inlet damper is ordered, it will ship mounted in the support stand.
6. Refer to page 35 for unit weights.

Dimension and Weights

Accessories

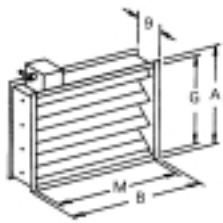

INLET DAMPER

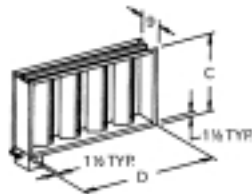

DISCHARGE DAMPER

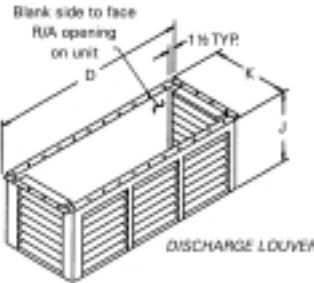

DISCHARGE LOUVER

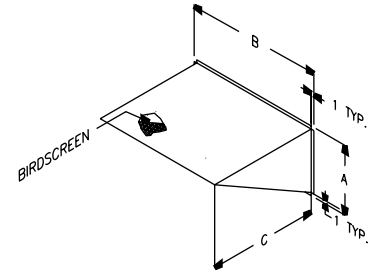

FOR MODELS 109-112

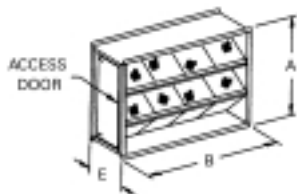

V-BANK FILTER

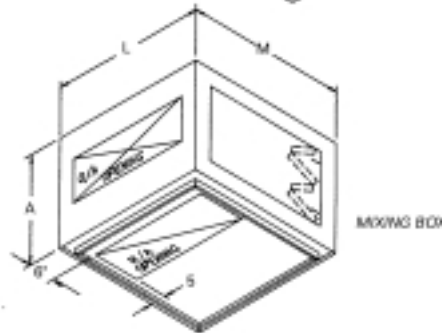

MIXING BOX

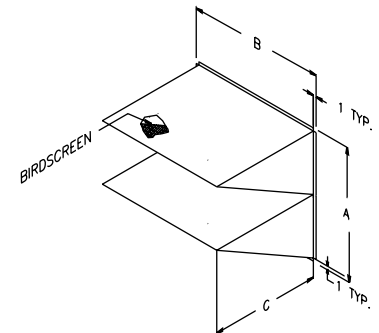

FOR MODELS 115-118, 215-218, 220-222

Table DW-13

Model	R/A/I.D.
109-118	3' 6" x 1' 8-1/4" (1067 x 514)
215-218	7' x 1' 8-1/4" (2134 x 514)
220-222	10' x 1' 8-1/4" (3048 x 514)
225-230	12' x 2' 2-1/2" (3658 x 673)

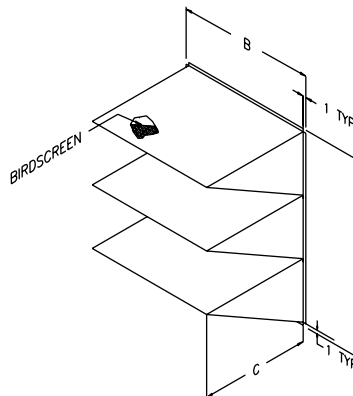

FOR MODELS 225-230

**NOTE: ALL DIMENSIONS IN INCHES
SUBJECT TO MANUFACTURING
TOLERANCES.**

Table DW-14

Model	A	B	C	D	F	F	G	H	J	K	L	M	Filters [Qty] Size
109-112	3' 0" (914)	3' 11-1/4" (1200)	1' 5-7/16" (443)	1' 8-13/16" (529)	1' 10" (559)	5' 1-3/4" (1568)	2' 8-1/4" (819)	3' 7-1/8" (1095)	1' 9" (533)	1' 11" (584)	4' 4" (1321)	4' 6" (1372)	[9] 15x20x2" (381x508x51)
115-118	3' 0" (914)	3' 11-1/4" (1200)	1' 10-7/8" (581)	2' 2-15/16" (684)	1' 10" (559)	5' 1-3/4" (1568)	2' 8-1/4" (819)	3' 7-1/8" (1095)	2' 0" (610)	2' 2" (660)	4' 4" (1321)	4' 6" (1372)	[9] 15x20x2" (381x508x51)
215-218	3' 0" (914)	7' 7-1/2" (2324)	1' 10-7/8" (581)	5' 4-7/8" (1648)	1' 10" (559)	5' 1-3/4" (1568)	2' 8-1/4" (819)	7' 3-3/8" (2219)	2' 0" (610)	2' 2" (660)	7' 10" (2388)	4' 6" (1372)	[18] 15x20x2" (381x508x51)
220-222	4' 0" (1219)	8' 5-5/8" (2581)	2' 7-1/4" (794)	7' 0-1/2" (2146)	1' 10" (559)	5' 5-3/4" (1670)	3' 8-1/4" (1124)	8' 1-1/2" (2477)	3' 9" (1143)	2' 7" (787)	10' 10" (3302)	5' 0" (1524)	[25] 20x20x2" (508x508x51)
225-230	5' 0" (1524)	10' 1-3/8" (3083)	3' 4-3/4" (1035)	8' 9-3/8" (2677)	2' 4" (711)	7' 2-1/8" (2188)	4' 8-1/4" (1429)	9' 9-3/8" (2978)	3' 9" (1143)	3' 4-3/4" (1035)	12' 10" (3912)	5' 5" (1651)	[36] 20x25x2" (508x635x51)

Note:

*Permanent filters are constructed of aluminum mesh.

Dimension and Weights

Roof Curbs

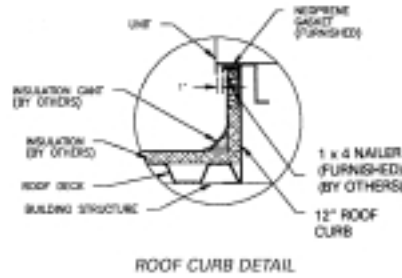
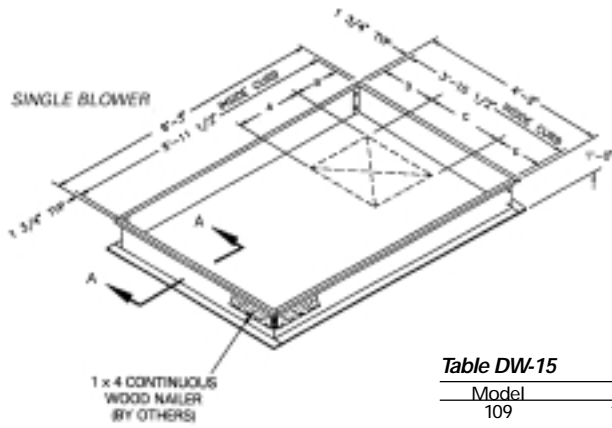

Table DW-15

Model	A	B	C	D	E
109	10 ^{-3/8"} (264)	1' 0 ^{-3/8"} (314)	11 ^{-15/16"} (303)	11 ^{-3/4"} (298)	1' 10 ^{-13/16"} (579)
112	1' 1 ^{-9/16"} (344)	10 ^{-13/16"} (275)	1' 3 ^{-15/16"} (405)	9 ^{-7/8"} (251)	1' 8 ^{-7/8"} (530)
115	1' 4" (406)	9 ^{-5/8"} (244)	1' 6 ^{-15/16"} (481)	8 ^{-3/8"} (213)	1' 7 ^{-3/8"} (492)
118	1' 7" (483)	9 ^{-5/8"} (244)	1' 10 ^{-1/16"} (560)	5 ^{-1/8"} (130)	1' 7 ^{-3/8"} (492)

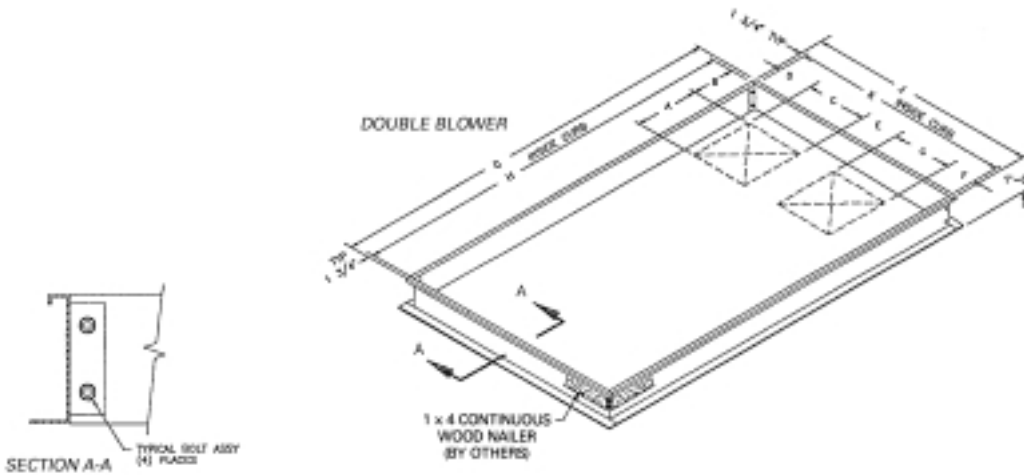

Table DW-16

Model	A	B	C	D	E	F	G	H	J	K
215	1' 4" (406)	9 ^{-5/8"} (244)	1' 6 ^{-15/16"} (481)	5 ^{-1/8"} (130)	1' 10 ^{-1/2"} (572)	1' 11 ^{-3/8"} (594)	6' 3" (1905)	5' 11 ^{-1/2"} (1816)	7' 8" (2337)	7' 4 ^{-1/2"} (2248)
218	1' 7" (483)	9 ^{-5/8"} (244)	1' 10 ^{-1/16"} (560)	5 ^{-1/8"} (130)	1' 4" (406)	1' 11 ^{-3/8"} (594)	6' 3" (1905)	5' 11 ^{-1/2"} (1816)	7' 8" (2337)	7' 4 ^{-1/2"} (2248)
220	2' 0 ^{-7/8"} (632)	10 ^{-7/16"} (265)	2' 1 ^{-1/16"} (637)	9 ^{-5/8"} (244)	2' 5 ^{-1/2"} (749)	2' 11 ^{-1/2"} (902)	7' 10" (2388)	7' 6 ^{-1/2"} (2299)	10' 8" (3251)	10' 4 ^{-1/2"} (3162)
222	2' 3 ^{-3/8"} (695)	10 ^{-7/16"} (265)	2' 3 ^{-9/16"} (700)	9 ^{-5/8"} (244)	2' 0 ^{-5/8"} (625)	2' 11 ^{-1/2"} (902)	7' 10" (2388)	7' 6 ^{-1/2"} (2299)	10' 8" (3251)	10' 4 ^{-1/2"} (3162)
225	2' 7 ^{-3/8"} (797)	1' 2 ^{-13/16"} (376)	2' 7 ^{-1/2"} (800)	1' 0 ^{-5/8"} (321)	3' 1 ^{-5/8"} (956)	2' 11 ^{-1/2"} (902)	7' 10" (2388)	7' 6 ^{-1/2"} (2299)	12' 8" (3861)	12' 4 ^{-1/2"} (3772)
230	3' 0 ^{-7/8"} (937)	1' 2 ^{-13/16"} (376)	3' 1" (940)	1' 0 ^{-5/8"} (321)	2' 2 ^{-5/8"} (676)	2' 11 ^{-1/2"} (902)	7' 10" (2388)	7' 6 ^{-1/2"} (2299)	12' 8" (3861)	12' 4 ^{-1/2"} (3772)

Notes:

1. Curb to be shipped loose and assembled in the field.
2. Curb must be square and level.
3. Curb requires intermediate structural support and is not to be corner post mounted.
4. Gaskets to be shipped with unit.
5. Bolting accessories shipped with curb.
6. Curb drawings shown are for units which have controls on the "standard" side.
7. Available on horizontal units only.

Dimension and Weights

Roof Curbs for Units with Return Air Opening Downstream of Burner

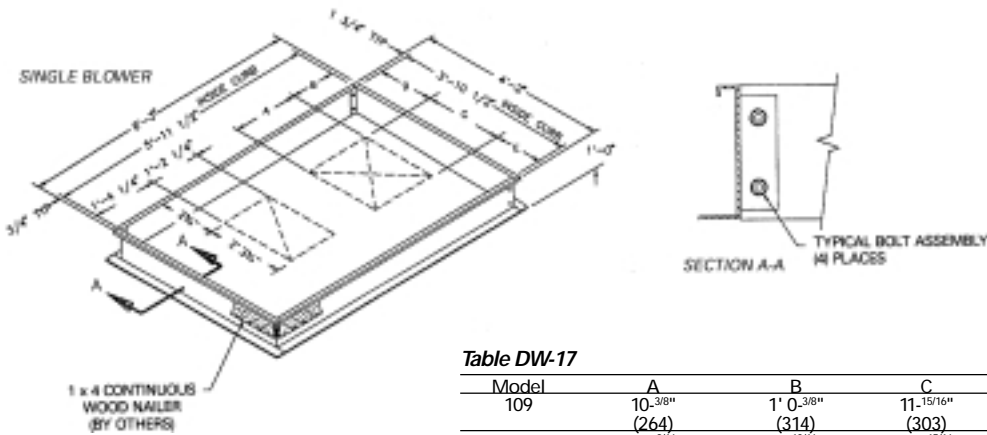

Table DW-17

Model	A	B	C	D	E
109	10-3/8" (264)	1' 0-3/8" (314)	11-15/16" (303)	11-3/4" (298)	1' 10-13/16" (579)
112	1' 1-9/16" (344)	10-13/16" (275)	1' 3-15/16" (405)	9-7/8" (251)	1' 8-7/8" (530)
115	1' 4" (406)	9-5/8" (244)	1' 6-15/16" (481)	8-3/8" (213)	1' 7-3/8" (492)
118	1' 7" (483)	9-5/8" (244)	1' 10-1/16" (560)	5-1/8" (130)	1' 7-3/8" (492)

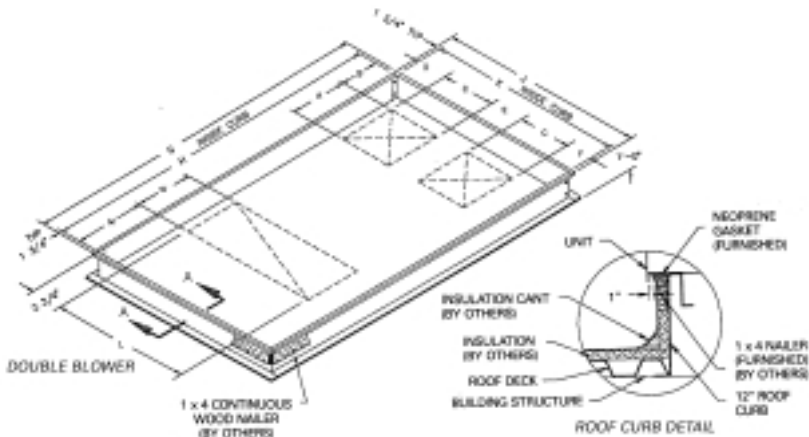

Table DW-18

Model	A	B	C	D	E	F	G	H	J	K	L	M	W
215	1' 4" (406)	9-5/8" (244)	1' 6-15/16" (481)	5-1/8" (130)	1' 10-1/2" (572)	1' 11-3/8" (594)	6' 3" (1905)	5' 11-1/2" (1816)	7' 8" (2337)	7' 4-1/2" (2248)	5' 5-3/4" (1670)	1' 4-1/4" (413)	1' 2-1/4" (362)
218	1' 7" (483)	9-5/8" (244)	1' 10-1/16" (560)	5-1/8" (130)	1' 4" (406)	1' 11-3/8" (594)	6' 3" (1905)	5' 11-1/2" (1816)	7' 8" (2337)	7' 4-1/2" (2248)	5' 5-3/4" (1670)	1' 4-1/4" (413)	1' 2-1/4" (362)
220	2' 0-7/8" (632)	10-7/16" (265)	2' 1-1/16" (637)	9-5/8" (244)	2' 5-1/2" (749)	2' 11-1/2" (902)	7' 10" (2388)	7' 6-1/2" (2299)	10' 8" (3251)	10' 4-1/2" (3162)	7' 3-3/8" (2219)	1' 4-1/4" (413)	1' 2-1/4" (362)
222	2' 3-3/8" (695)	10-7/16" (265)	2' 3-9/16" (700)	9-5/8" (244)	2' 0-5/8" (625)	2' 11-1/2" (902)	7' 10" (2388)	7' 6-1/2" (2299)	10' 8" (3251)	10' 4-1/2" (3162)	7' 3-3/8" (2219)	1' 4-1/4" (413)	1' 2-1/4" (362)
225	2' 7-3/8" (797)	1' 2-13/16" (376)	2' 7-1/2" (800)	1' 0-5/8" (321)	3' 1-5/8" (956)	2' 11-1/2" (902)	7' 10" (2388)	7' 6-1/2" (2299)	12' 8" (3861)	12' 4-1/2" (3772)	9' 3-3/8" (2829)	9-1/16" (230)	1' 8-1/4" (514)
230	3' 0-7/8" (937)	1' 2-13/16" (376)	3' 1" (940)	1' 0-5/8" (321)	2' 2-5/8" (676)	2' 11-1/2" (902)	7' 10" (2388)	7' 6-1/2" (2299)	12' 8" (3861)	12' 4-1/2" (3772)	9' 3-3/8" (2829)	9-1/16" (230)	1' 8-1/4" (514)

Notes:

1. Curb to be shipped loose and assembled in the field.
2. Curb must be square and level.
3. Curb requires intermediate structural support and is not to be corner post mounted.
4. Gaskets to be shipped with unit.
5. Bolting accessories shipped with curb.
6. Curb drawings shown are for units which have controls on the "standard" side.
7. Available on horizontal units only.

Dimension and Weights

Roof Curbs for Units with Mixing Box

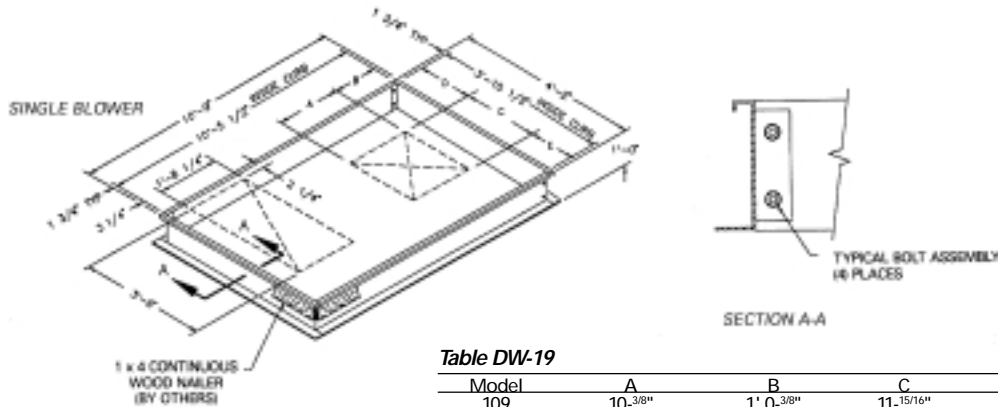

Table DW-19

Model	A	B	C	D	E
109	10'-3/8" (264)	1'-0'-3/8" (314)	11'-15/16" (303)	11'-3/4" (298)	1'-10'-13/16" (579)
112	1'-1'-9/16" (344)	10'-13/16" (275)	1'-3'-15/16" (405)	9'-7/8" (251)	1'-8'-7/8" (530)
115	1'-4" (406)	9'-5/8" (244)	1'-6'-15/16" (481)	8'-3/8" (213)	1'-7'-3/8" (492)
118	1'-7" (483)	9'-5/8" (244)	1'-10'-1/16" (560)	5'-1/8" (130)	1'-7'-3/8" (492)

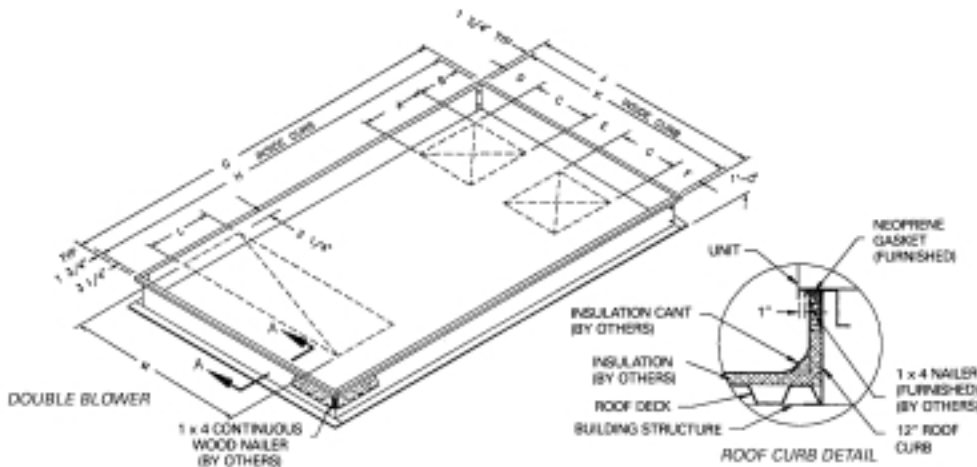

Table DW-20

Model	A	B	C	D	E	F	G	H	J	K	L	M
215	1'-4" (406)	9'-5/8" (244)	1'-6'-15/16" (481)	5'-1/8" (130)	1'-10'-1/2" (572)	1'-11'-3/8" (594)	10'-9" (3277)	10'-5-1/2" (3188)	7'-8" (2337)	7'-4-1/2" (2248)	1'-8-1/4" (514)	7'-0" (2134)
218	1'-7" (483)	9'-5/8" (244)	1'-10'-1/16" (560)	5'-1/8" (130)	1'-4" (406)	1'-11'-3/8" (594)	10'-9" (3277)	10'-5-1/2" (3188)	7'-8" (2337)	7'-4-1/2" (2248)	1'-8-1/4" (514)	7'-0" (2134)
220	2'-0'-7/8" (632)	10'-7/16" (265)	2'-1'-11/16" (637)	9'-5/8" (244)	2'-5'-1/2" (749)	2'-11'-1/2" (902)	12'-10" (3912)	12'-6-1/2" (3823)	10'-8" (3251)	10'-4-1/2" (3162)	1'-8-1/4" (514)	10'-0" (3048)
222	2'-3'-3/8" (695)	10'-7/16" (265)	2'-3'-9/16" (700)	9'-5/8" (244)	2'-0'-5/8" (625)	2'-11'-1/2" (902)	12'-10" (3912)	12'-6-1/2" (3823)	10'-8" (3251)	10'-4-1/2" (3162)	1'-8-1/4" (514)	10'-0" (3048)
225	2'-7'-3/8" (797)	1'-2'-13/16" (376)	2'-7'-1/2" (800)	1'-0'-5/8" (321)	3'-1'-5/8" (956)	2'-11'-1/2" (902)	13'-4" (4064)	13'-1/2" (3950)	12'-8" (3861)	12'-4-1/2" (3772)	2'-2'-1/2" (673)	12'-0" (3658)
230	3'-0'-7/8" (937)	1'-2'-13/16" (376)	3'-1" (940)	1'-0'-5/8" (321)	2'-2'-5/8" (676)	2'-11'-1/2" (902)	13'-4" (4064)	13'-1/2" (3950)	12'-8" (3861)	12'-4-1/2" (3772)	2'-2'-1/2" (673)	12'-0" (3658)

Notes:
 1. Curb to be shipped loose and assembled in the field.
 2. Curb must be square and level.
 3. Curb requires intermediate structural support and is not to be corner post mounted.
 4. Gaskets to be shipped with unit.
 5. Bolting accessories shipped with curb.
 6. Curb drawings shown are for units which have controls on the "standard" side.
 7. Available on horizontal units only.

Dimension and Weights

Approximate Weights

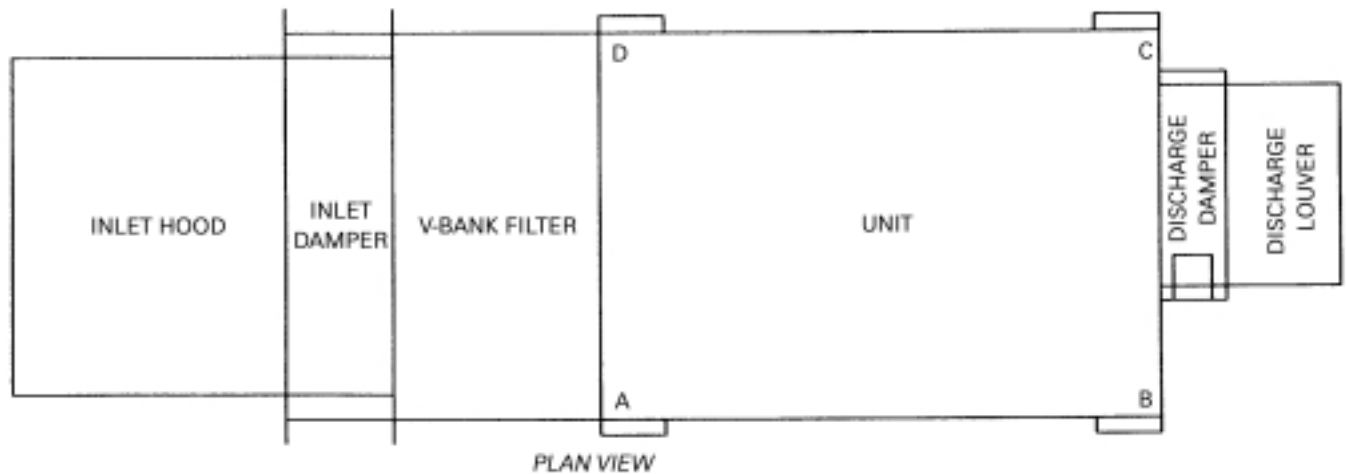

Table W-1 — Outdoor Unit Weights in Pounds (Approximate)*

Unit Size	Basic Horizontal Unit	Basic Vertical Unit	Inlet Hood	Inlet Damper	V-Bank Filter	Mixing Box	Discharge Damper	Discharge Louver	A	B	C	D
109	760	1010	140	60	125	320	45	70	215	215	185	145
112	760	1010	140	60	125	320	45	70	215	215	185	145
115	760	1010	140	60	125	320	45	70	215	215	185	145
118	820	1060	140	60	125	320	45	70	225	225	200	160
215	1180	1650	210	160	200	586	80	150	342	342	274	222
218	1300	1770	210	160	200	586	80	150	378	378	311	233
220	2280	3270	275	210	250	730	145	215	625	625	555	475
222	2370	3360	275	210	250	730	145	215	675	675	545	475
225	2990	4250	365	320	330	1006	190	230	824	824	732	610
230	3130	4390	365	320	330	1006	190	230	863	863	731	673

Note:

*Contact factory for shipping weight on models exceeding 50,000 CFM.

Table W-2 — Roof Curb Weights in Pounds

Description	Unit Size									
	109	112	115	118	215	218	220	222	225	230
Roof Curb for Basic Frame—No Return Air	150	150	150	150	200	200	270	270	300	300
Roof Curb for Basic Frame—With Return Air Downstream of Burner	150	150	150	150	200	200	270	270	300	300
Roof Curb for Basic Frame—With Mixing Box Option	215	215	215	215	270	270	340	340	375	375



Mechanical Specifications

General

The BASIC unit is factory-assembled, wired and test-fired. DEPENDING ON THE OPTIONS, UNIT MAY SHIP IN SECTIONS DUE TO PHYSICAL SIZE OF EQUIPMENT. Although designed primarily for outdoor mounting, it can be mounted indoors. Units are mounted on steel rails with lifting lugs, which make them suitable for curb or slab mounting. Units are available for operation on either natural or LP (propane) gas.

Casing

Basic unit casings are fabricated of die-formed galvanized steel. Unit sizes 109-220 shall be 18-gauge. Unit sizes 225-230 shall be 18-gauge, except exterior walls which are 16-gauge.

Access doors are hinge-mounted with industrial-type hardware for easy access to service compartments.

All casings shall be airtight and weatherproof. Complete access shall be provided to all components through gasketed access doors or panels. This includes the motor, blower, burner, electrical components, and manifold sections.

Fans

Supply fans shall be double width, double inlet centrifugal type with FC fan wheels. Fans are tested in accordance with AMCA 210. The fan or fans shall be mounted on a heavy-duty polished steel shaft designed for a maximum operating speed not to exceed 75 percent of its first critical speed. Bearings are to be heavy-duty, industrial prelubricated type. Bearing life is 100,000 hours.

Blowers are driven by a V-belt package sized with a capacity of 25 percent greater than the motor horsepower. Multiple belt applications will be matched sets. Drives are adjustable pitched diameter type up through 7½ hp, fixed on motors over 7½ hp.

Burner Section

The burner section shall contain a Maxon NP burner constructed of rust-resistant cast iron bodies (which serve as the gas manifold) drilled to discharge the fuel between diverging #321 stainless steel mixing plates. The entire burner assembly is mounted directly in the air stream being heated. The fresh air stream passes through the mixing plates and mixes with the fuel as combustion air; thus, all available heat from the gaseous fuel is released directly into the air stream. Air velocities across the burner assemblies are established by the use of profile plates.

The manifold is located outside of the airstream and shielded from atmospheric conditions by means of a protective compartment with hinged access. An observation port shall be located to provide view of the pilot and main flame.

Units shall be supplied with a wide-range burner with a modulating turndown ratio of 25 to 1. Adjustable profile plates shall be provided and sized to maintain the required velocity across the line burner. The operation of the burner shall be programmed through the flame safeguard with timed prepurge and flame sensing.

Control Enclosure

Units shall be provided with a control compartment. All controls mounted within this compartment are to be wired to a numbered terminal strip. All wiring is to be color coded and in accordance with NEC. A circuit diagram of the approved electrical drawing shall be provided with the unit. All electrical components shall bear the UL label.

Controls

Unit controls shall consist of a spark ignition system with a flame rod sensing the flame, a high temperature limit switch set at 185 F, a flame safeguard with alarm contacts, ignition transformer, air proving differential switch, timed freeze protection, and a series 14 or 44 modulating control system.

The unit shall also contain a main fan starter and overloads, control circuit fuses, and vents for outdoor units.

Gas Train Approvals

The standard gas train consists of a main manual gas shutoff valve, a motorized electric main gas valve, the Maxitrol modulating gas valve, a manual pilot gas shutoff valve, a manual pilot gas pressure regulator, a pilot gas valve, an orificed needle valve, and an auxiliary gas valve.

The Factory Mutual (FM) gas train consists of a manual main gas shutoff valve, a motorized electric main gas valve, the Maxitrol modulating gas valve, a manual pilot gas shutoff valve, a manual pilot gas pressure regulator, a pilot gas valve, an orificed needle valve, a high/low gas pressure switch, a manual auxiliary gas shutoff valve, and an auxiliary gas valve. (Optional)

The Industrial Risk Insurers (IRI) gas train consists of a manual main gas shutoff valve, a motorized electric main gas valve, the Maxitrol modulating gas valve, a manual pilot gas shutoff valve, a manual pilot gas pressure regulator, a pilot gas valve, an orificed needle valve, a high/low gas pressure switch, a manual auxiliary gas shutoff valve, a normally open vent valve, and an auxiliary gas valve. (Optional)

Options

Motorized Return Air Damper

Purpose

To provide a way for recirculating return air.

Operation

A two position switch controls the return air damper.

When the two position switch is in the "RA" position, the RA damper opens. Fifty percent of supply air is RA, 50 percent of supply air is OA.

RA damper can be set to allow from 0 percent to 50 percent return air by field adjustment of the linkage rods. The gas valve opening is restricted when the RA damper is open.

Code requires that outside ventilation air be provided to the space in the amount of 4 cfm per 1 MBh of burner rated input.

All units are provided with a means that will allow the customer to interlock OA fans when the amount of OA provided by the unit is not sufficient to meet the 4 cfm per 1 MBh requirement.

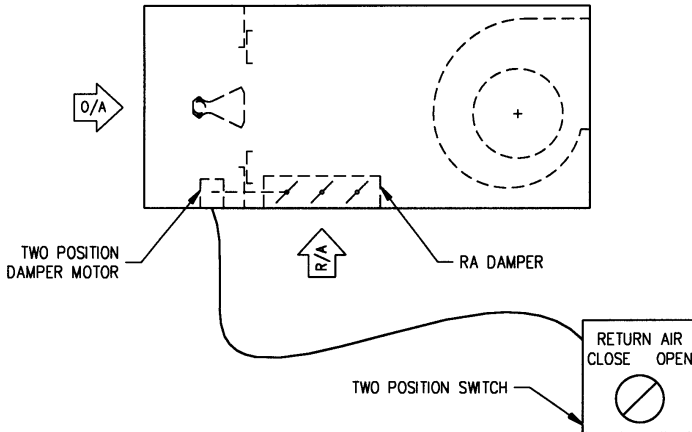

When the two position switch is in the "OA" position, the RA damper is closed, and 100 percent of supply air is OA.

Note: This option cannot be used with a two speed fan motor.

Note: This option can be used with either the Motorized Inlet Damper option or the Motorized Outlet Damper option.

- Option Includes:
- Return air damper
 - Two position damper motor
 - Damper switch

Motorized 75/25 Damper

Purpose

To provide a way for recirculating return air and letting building pressure control the amount of air which is recirculated.

Operation

If building pressure is less than desired, the RA damper modulates to a more closed position and the interlocked burner profile damper modulates to a more open position. More OA is brought into building.

If building pressure is greater than desired, the RA damper modulates to a more open position and the interlocked burner profile damper modulates to a more closed position. Less OA is brought into building.

At no time will the unit provide less than 25 percent OA to the building. In general terms, the minimum OA is 25 percent; however, there are cases where it can be as high as 40-50 percent, depending upon unit size, burner size, gas train type and gas pressure.

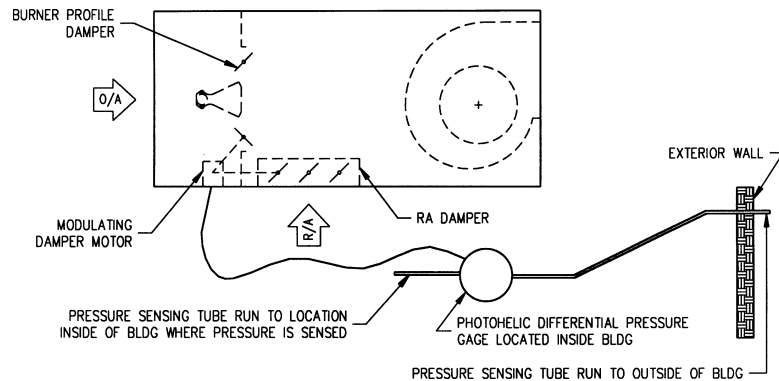

Code requires that outside ventilation air be provided to the space in the amount of 4 cfm per 1 MBh of burner rated input.

All units are provided with a means that will allow the customer to interlock OA fans when the amount of OA provided by the unit is not sufficient to meet the 4 cfm per 1 MBh requirement.

Note: This option cannot be used with a two speed fan motor.

Note: This option can be used with either the Motorized Inlet Damper option or the Motorized Outlet Damper option.

- Option Includes:
- Return air damper
 - Burner profile damper
 - Linkage
 - Modulating damper motor(s)
 - Photohellic differential pressure gauge

Options

Mixing Box — Temperature Control

Purpose

To provide a way for recirculating return air and letting mixed air temperature determine the amount of OA/RA.

Operation

A temperature sensor located after the V-bank filter modulates the OA and RA dampers to maintain a set temperature. If temperature at sensor is cooler than setting, OA damper modulates to a more closed position, and RA damper modulates to a more open position. If temperature at sensor is warmer than setting, OA damper modulates to a more open position, and RA damper modulates to a more closed position.

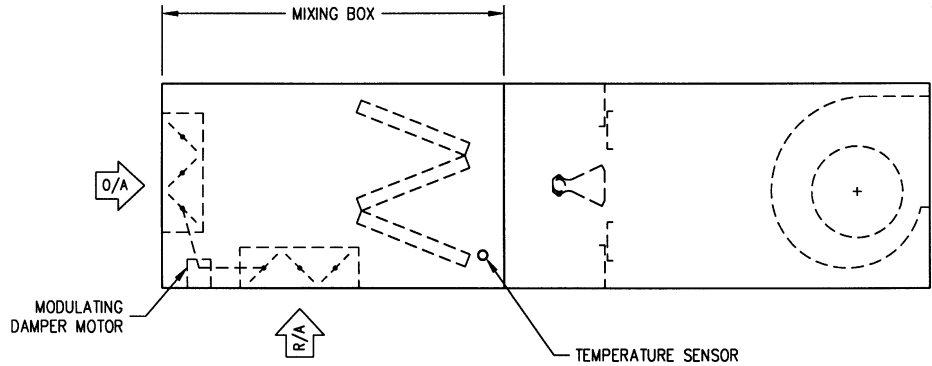

The minimum OA damper position is factory set with a potentiometer. The minimum OA damper position is set at 4 cfm per 1 MBh of burner rated input, or 25% supply air, whichever is larger.

The desired temperature at the temperature sensor is set at the control cabinet at the unit.

Option Includes:

- Mixing box with V-bank filter and permanent filters
- Dampers
- Modulating damper motor(s)
- Temperature sensor

Mixing Box — Manual Control

Purpose

To provide a way for recirculating return air and using manual control to determine the amount of OA/RA.

Operation

A manual potentiometer located at the remote control station determines the OA/RA setting. The minimum OA damper position is factory set with a potentiometer. The minimum OA damper opening is set at 4 cfm per 1 MBh of burner rated input, or 25% supply air, whichever is larger.

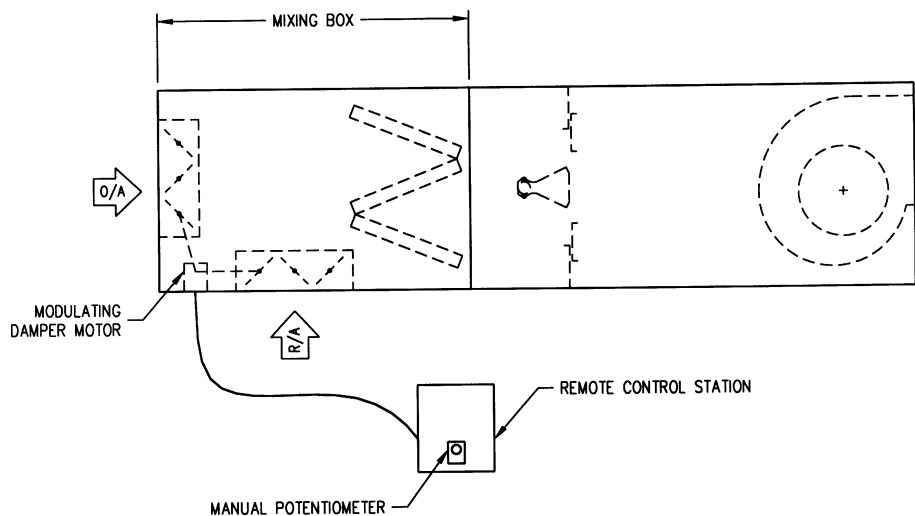

Option Includes:

- Mixing box with V-bank filter and permanent filters
- Dampers
- Modulating damper motor(s)
- Manual potentiometer

Note: Remote control station not included.

Options

Mixing Box — Building Pressure Control

Purpose

To provide a way for recirculating return air and letting building pressure control the amount of air which is recirculated.

Operation

If building pressure is less than desired, the RA damper modulates to a more closed position and the OA damper modulates to a more open position. More OA is brought into building.

If building pressure is greater than desired, the RA damper modulates to a more open position and the OA damper modulates to a more closed position. Less OA is brought into building.

The minimum OA damper position is factory set with a potentiometer. The minimum OA damper position is set at 4 cfm per 1 MBh of burner rated input, or 25% supply air, whichever is larger.

The desired pressure differential is set at the photohelic.

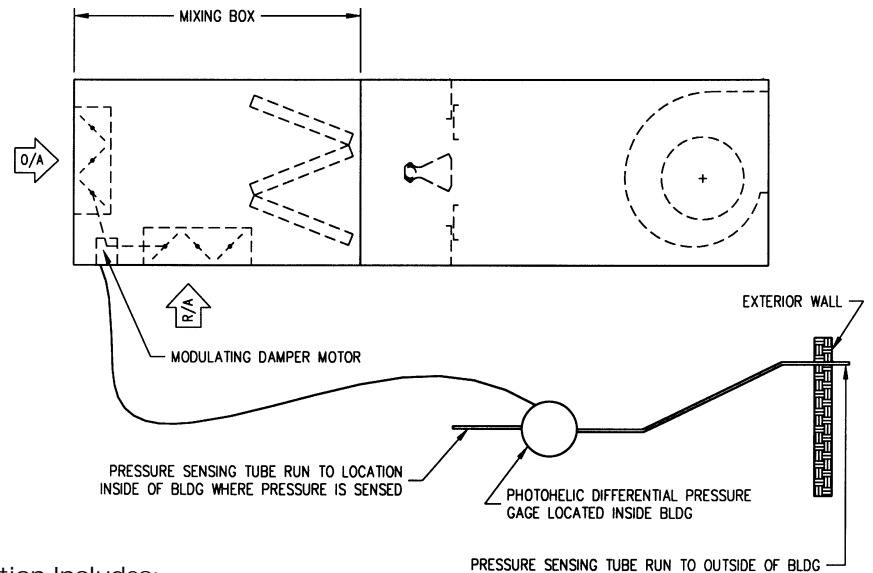

Option Includes:

- Mixing box with V-bank filter and permanent filters
- Dampers
- Modulating damper motor(s)
- Photohelic differential pressure gauge

Motorized Inlet Damper

Purpose

To provide a shut-off damper.

Operation:

When the fan switch is on, the inlet damper begins to open. As the inlet damper approaches the full open position, a built-in end switch located inside the damper motor closes. The closed end switch starts the fan motor. When the fan switch is turned to the "off" position, or if there is a power failure, the inlet damper closes.

Option Includes:

- Damper
- Two position damper motors with built-in end switch and spring return
- Linkage

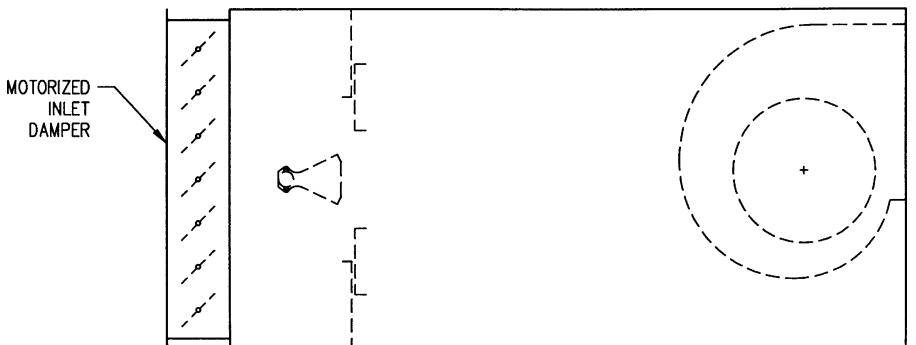

Options

Motorized Outlet Damper

Purpose

To provide a shut-off damper.

Operation

When the fan switch is on, the outlet damper begins to open. As the outlet damper approaches the full open position, a built-in end switch located inside the damper motor closes. The closed end switch starts the fan motor. When the fan switch is turned to the "off" position, or if there is a power failure, the outlet damper closes.

CGA Approval Requirements

A DFOA unit with no mixing box, motorized RA damper, or motorized 75/25 damper can bear the CGA label if:

- 1 The unit SCFM is less than the Maximum SCFM given below.
- 2 The unit input is less than the Maximum Input BTUH given below.
- 3 The static pressure is in the range given below.
- 4 Unit discharge temperature is 75 F maximum.
- 5 The ambient temperature is minus 40 F or greater.
- 6 The unit has a maximum temperature rise of 90 F for single blower units and 100 F for double blower units.
- 7 The unit minimum input rating is 1/25 of the Max. Input BTUH given below.
- 8 The fuel is natural gas.
- 9 The motor is a single speed motor.
- 10 Unit components are standard (there are exceptions to this).

Model No.	Static (in W.C.)	Max. SCFM	Max. Input. (BTUH)
DFOA 109	0-4.0	3,000	325,500
DFOA 112	0-4.0	4,250	461,125
DFOA 115	0-4.0	6,000	851,000
DFOA 118	0-4.0	8,500	922,250
DFOA 215	0-4.0	12,000	1,302,000
DFOA 218	0-4.0	17,000	1,844,500
DFOA 220	0-4.0	26,000	2,821,000
DFOA 222	0-4.0	31,000	3,363,500
DFOA 225	0-4.0	46,000	4,991,000
DFOA 230	0-3.5	64,000	6,944,000

Option Includes:

- Damper
- Two position damper motor with built-in end switch and spring return
- Linkage

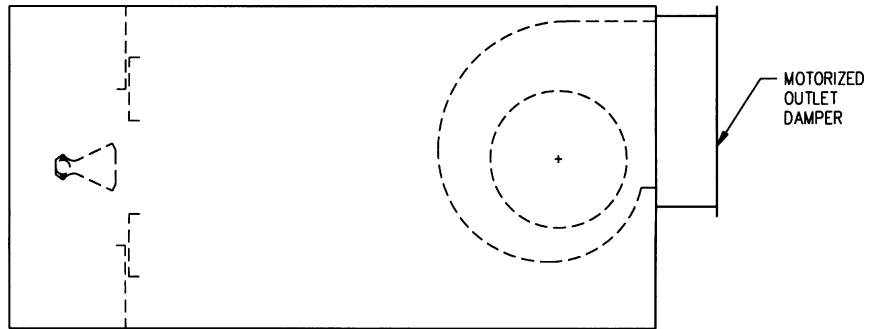

ETL Labeling Requirements

A DFOA unit with a mixing box, motorized RA damper, or motorized 75/25 damper can bear the ETL label if:

- 1 The unit SCFM is less than the Maximum SCFM given below.
- 2 The unit input is less than the Maximum BTUH rating given below.
- 3 The unit temperature rise is less than the Maximum Temperature Rise given below.
- 4 The fuel is natural gas.
- 5 The motor is a single speed motor.
- 6 Unit components are standard (there are exceptions to this).

Model No.	Max. SCFM	Max. BTUH	Max. Temp. Rise
DFOA 109	3,000	291,262	100 F
DFOA 112	4,250	412,621	100 F
DFOA 115	6,000	582,524	100 F
DFOA 118	8,500	680,000	100 F
DFOA 215	12,000	1,349,831	100 F
DFOA 218	18,000	1,800,000	100 F
DFOA 220	26,000	2,924,634	100 F
DFOA 222	31,000	3,100,000	100 F
DFOA 225	46,000	5,174,353	100 F
DFOA 230	64,000	6,400,000	100 F

ETL Labeling Requirements

A DFOA unit with no mixing box, motorized RA damper, or motorized 75/25 damper can bear the ETL label if:

- 1 The unit SCFM is less than the Maximum SCFM given below.
- 2 The unit input is less than the Maximum BTUH rating given below.
- 3 The unit temperature rise is less than the Maximum Temperature Rise given below.
- 4 The fuel is natural gas.
- 5 The motor is a single speed motor.
- 6 Unit components are standard (there are exceptions to this).

Model No.	Max. SCFM	Max. BTUH	Max. Temp. Rise
DFOA 109	3,000	424,565	120 F
DFOA 112	4,250	601,290	120 F
DFOA 115	6,000	848,880	120 F
DFOA 118	8,500	1,202,580	120 F
DFOA 215	12,000	1,697,760	120 F
DFOA 218	18,000	2,546,640	120 F
DFOA 220	26,000	3,678,480	120 F
DFOA 222	31,000	4,385,880	120 F
DFOA 225	46,000	6,508,080	120 F
DFOA 230	64,000	9,054,720	120 F

These requirements were current when this catalog was printed. Please contact Technical Support for the most current data available.

Options

Exhaust Interlock

The exhaust interlock is a pair of contacts on the unit that will close when the unit is "on." The customer can wire the exhaust fan to the contacts so that when the heating unit is "on," the exhaust fan will also be "on." Note the heating unit turns on the exhaust fan.

The auxiliary contacts on the fan motor starter are the contacts which are used as the exhaust interlock. The auxiliary contacts are wired to the numbered terminal strip. The customer can wire the indicated terminals into the control circuit of the exhaust fan.

Note: *If the customer wants the exhaust fan to turn the heating unit "on," he/she has to provide a pair of contacts that will close when the exhaust fan is "on."*

Interlocking Relay

The interlocking relay is two pair of contacts, one normally open and the other normally closed. The contacts switch positions when the unit is "on." The contacts are wired to the numbered terminal strip. The customer can wire a wide range of devices to the interlocking relay by wiring to the indicated terminals.

Seven Day Timeclock/ Night Setback Thermostat

The seven day timeclock is used primarily for either one of the following:

1

Start and stop the unit at preset times

Example: A building is occupied at 8:00 AM. At 4:30 PM, people leave the building. The timeclock could be set to turn the unit on at 7:30 AM and off at 5:00 PM.

2

The timeclock can be used with an on-off night setback thermostat (NSB thermostat). The timeclock and NSB thermostat would be wired so that during the night, the NSB thermostat would turn the unit on and off.

Example: Same as example above, only at 5:00 PM the NSB thermostat would turn the unit on and off. If the temperature in the space fell below the setting of the NSB thermostat, the unit would come "on." If the temperature rose above the setting, the unit would go "off."

Inlet On-Off Duct Stat

Automatically turns burner off when inlet air temperature equals setting of control. Works as a lockout for the burner.

Example: If we want the burner to be "off" if the entering air temperature is 65 degrees, the inlet on-off duct stat would be set at 65 degrees.

Without the inlet on-off duct stat, if the fan switch and heat switch are both "on," no matter how warm the incoming air, the burner will go as low as low fire, but will not go "off."

UV Flame Sensor (UV Mini-Peeper)

Flame sensor checks to make sure the pilot flame has ignited before gas is sent to the main burner. Operates by sensing the light of the pilot flame.

If the flame sensor does not sense the pilot flame, the unit shuts down (fan and burner go off) and the flame failure light on the optional remote panel goes on.

The unit has to be reset by pushing the reset button on the burner relay.

Differences between UV Flame Sensor and Flame Rod:

Both are used for the same purpose — to check if the pilot flame is on. The flame rod is "standard." The UV sensor needs to be ordered as an option.

If condensation forms on the flame rod while the unit is off, it may give a false signal and prevent the unit from coming on. The wet flame rod does not sense the pilot flame and shuts the unit down. This nuisance tripping can be avoided with the UV flame sensor.

Optional Gas Controls

Series 14 — Constant Discharge Temperature

The constant discharge temperature, gas modulating control system consists of the Maxitrol electronic gas modulating system (55 to 90 F range), which includes a discharge air sensor located in the blower discharge, a modulator/regulator valve mounted in the gas piping manifold, an amplifier installed in the electrical control panel, a 115 to 24 volt transformer, and a remote temperature selector.

Series 44 — Space Temperature Control

The space temperature control, gas modulating control system consists of the Maxitrol electronic gas modulating system, which includes a Series 44 discharge air sensor (55 to 90 F range) mounted in the blower discharge, a modulator regulator valve mounted in the gas piping manifold, an amplifier installed in the electric control panel, a 115 to 24 volt transformer, and a Selectrstat mounted in the area where the temperature is to be sensed.



Options

Factory Installed Options

Motors — General

All motors are provided as standard, with a starter for external overload protection, a control transformer, and a fusible disconnect switch.

Open Drip-Proof Motor 60 Hz/1800 Rpm

Single Phase

Optional 115V motors are available in ¾ to 3 hp models. Optional 208V motors are available in ¾ to 7½ hp models. Optional 230V motors are available in ¾ to 10 hp models. All motors have rigid base construction and ball bearings. Class A insulation is on all motors up to and including 3 hp models. Class B insulation is on 5 hp and above models.

Three-Phase

Optional 208, 230, 460V available in 1 to 60 hp models. All models have rigid base construction and ball bearings. Class B insulation is on all three-phase motors.

Energy Efficient ODP 60 Hz/1800 Rpm

Three-Phase Only

Optional 208V motors are available in 1 to 30 hp models. 230 and 460V motors are available in 1 to 60 hp models. All motors have rigid base construction and ball bearings. Class B insulation is on all motors.

Totally Enclosed Motor 60 Hz/1800 Rpm

Three-Phase Only

Optional 208V motors are available in ¾ to 20 hp models. Optional 230 and 460V motors are available in ¾ to 60 hp models. All motors have rigid base construction and ball bearings.

Energy Efficient TEFC 60 Hz/1800 Rpm

Three-Phase Only

Optional 208V motors are available in 1 to 30 hp models. 230 and 460V motors are available in 1 to 60 hp models. All motors have rigid base construction and ball bearings. Class B insulation is on all motors.

Two-Speed/One Winding Motors 60 Hz/1800/900 Rpm

Three-Phase Only

Optional 208 and 230V motors available on 1 to 20 hp models. Optional 460V motors are available on 1 to 50 hp models. All motors have rigid base construction and ball bearings. Class B insulation is on all motors.

Two-Speed/Two Winding Motors 60 Hz/1800/1200 Rpm

Three-Phase Only

Optional 208 and 230V motors available on 1 to 20 hp models. Optional 460V motors are available on 1 to 50 hp models. All motors have rigid base construction and ball bearings. Class B insulation is on all motors.

Additional Options*

Inlet Hood and Birdscreen

Hood constructed of 18-gauge galvanized steel. Birdscreen is 18-gauge galvanized steel with one-inch square openings.

V-Bank Filter Section

Not required when a mixing box is specified. Constructed of 18-gauge galvanized steel.

Dampers and Mixing Box

Motorized Return Air Damper

This option provides a way to recirculate air, with the return air opening downstream of the burner. This option includes return air damper, a two-position damper motor, linkage and damper switch. It is not available with two-speed motors.

Motorized 75/25 Damper

This option provides a way for recirculating return air and allows building pressure to control the amount of air that is recirculated. This option includes a return air damper, burner profile plate damper, damper linkage, and modulating pressure controller. It is not available with two-speed motors.

Mixing Box — Temperature Control

This option provides a way for recirculating return air and allows mixed air temperature to determine the amount of OA/RA. This option includes mixing box with filter section, dampers, damper actuator(s), and damper controls.

Mixing Box — Building Pressure Control

This option provides a way for recirculating return air and allows building pressure to control the amount of air which is recirculated. This option includes a mixing box with filter section, dampers, damper actuator(s), and damper controls (including a photohelic differential pressure gauge).

Mixing Box — Manual Control

This option provides a way for recirculating return air and using manual control to determine the amount of OA/RA. This option includes a mixing box with filter section, dampers, damper actuator(s), and a manual potentiometer.

Inlet/Outlet Dampers

Motorized Inlet Damper

This option provides a shutoff damper. This option includes an outside air damper, damper motor with built-in end switch, and linkage. It is not available with a mixing box.

Motorized Outlet Damper

This option provides a shutoff damper. This option includes a discharge damper, two-position damper motor with a built-in end switch, and linkage.

**Based on unit design, some options can ship factory installed or field installed. Contact the factory for verification.*

Accessories

Additional Factory Installed Options

High Gas Pressure Regulator 1-5 Psig

Units 825 MBh and less require an additional gas pressure regulator if inlet pressure exceeds 1 psig. Inlet pressure at the job must be specified.

5-10 Psig

An additional regulator is furnished. Inlet pressure at the job must be specified.

Insulation

One-inch, 1½ lb. fiberglass insulation pin spotted to casing.

Insulation on Basic Frame

Insulation on Filter Section

Internal Blower/Motor Isolation

This option includes a steel frame for blower(s) and a fan motor with spring type vibration isolators. It is not available on vertical units.

Extended Grease Lines

This option allows lubrication of fan bearings from the control side of the unit.

Controls Opposite from Standard

Inlet On-Off Duct Stat

This automatically turns the burner off when inlet air temperature equals desired discharge air temperature. It works as a lockout for the burner. Temperature range of 25 to 225 SPDT.

115V Duplex Receptacle

This option includes a transformer and disconnect switch for the receptacle. Components are mounted in the gas piping manifold.

Circuit Analyzer

Provides indicator lights for maintenance troubleshooting. If the unit is not functioning properly, the service person will want to know which circuits are open and which are closed. The circuit analyzer will tell the service person, at a glance, the status (open or closed) of the different circuits. If an indicating light is lit, the circuit is in its correct operating mode. It mounts on the control panel of the unit. The number of lights and functions depends on the control options of the unit.

UV Flame Sensor

The flame sensor checks to make sure the pilot flame has ignited before gas is sent to the main burner. It operates by sensing the light of the pilot flame.

Clogged Filter Switch

This option includes a pressure sensing switch which senses the pressure drop across the filters. When the pressure drop reaches the setpoint, the switch trips and lights the clogged filter light. It is not required when City of Chicago controls are ordered.

Exhaust Fan Interlock

This option includes a pilot duty rated normally open contact on the main supply fan motor starter that will close simultaneously with the starter (10 amp contacts).

Interlocking Relay

This option is energized by an auxiliary contact on the supply fan motor starter that can be used for additional equipment that may need to run when the supply fan is running (12 amp contacts).

City of Chicago Controls

This option includes an access door interlock switch, an alarm horn with silence switch, low temperature limit, and a clogged filter switch.

Field Installed Accessories

Vibration Feet

Rubber-in-shear vibration isolators cannot be ordered with a roof curb — they ship unmounted.

Vibration Feet — Basic Frame

Vibration Feet — Filter Section

Vibration Feet — Mixing Box

Seven-Day Time Clock

This option includes a Paragon seven-day general purpose time control with a four-pole switch.

100 DBL Alarm Horn and Silencing Switch

The alarm horn and silencing switch are field-wired so that if the pilot flame does not ignite, the alarm sounds. To silence the alarm, the push button silencing switch is pushed.

Remote Control Station

Option includes fan and heat switches, burner on light, alarm light, and Maxitrol Selector or Selectrastat.

On-Off Night Setback Thermostat

This option will shut unit off when space temperature is above setpoint. This is a 115V thermostat with a temperature range of 50 to 80 F. Option is normally used together with the seven-day timeclock option.

High Gas Pressure Regulator — Over 10 Psig

Specify inlet pressure at the jobsite. This is required for selection of the regulator.

Roof Curbs

Roof curbs are fabricated of 12-gauge galvanized steel. Curb gasket is provided. The 12-inch high roof curbs ship disassembled.

Roof Curb For Basic Frame — No return air

Roof Curb For Basic Frame — With return air downstream of the burner

Roof Curb For Basic Frame — With mixing box option



TRANE®

*The Trane Company
An American Standard Company
www.trane.com*

For more information contact your local district office, or e-mail us at comfort@trane.com

Literature Order Number	MUA-PRC001-EN
File Number	PL-UN-MUA-DFOA-PRC001-9-00
Supersedes	MUA-D-2 12/97
Stocking Location	Inland - LaCrosse

Since The Trane Company has a policy of continuous product and product data improvement, it reserves the right to change design and specifications without notice.